

Spray Guns

General Catalog

GENERAL CATALOG FOR SPRAY GUN & ACCESSORIES



APPLICATIONS FOR
GENERAL INDUSTRY & CAR REFINISHING

Active with Newest Technology

World-class quality, friendly to both humans and the environment



We offer HVLP spray guns featuring low over spray and high transfer efficiency, and reliable conventional spray guns. These products offer the performance needed to contribute to global environmental conservation.

Measures to preserve the environment are currently being implemented globally across industries to safeguard the future of our irreplaceable planet. We believe our mission as an industrial manufacturer is to develop advanced technologies friendly to both humans and the environment. In the paint and coating industries in Europe and the United States, both leaders in environmental conservation initiatives, rigorous laws and regulations governing paint solvent emissions have been enacted both nationally and regionally, with a special emphasis on the need to regulate volatile organic compounds (VOCs) and minimize industrial waste. These factors underscore the urgent demand in the Japanese coating industry for water-based and low-VOC paints that offer high transfer efficiency and low over spray.

In 1990, ANEST IWATA launched HVLP (High Volume Low Pressure) spray guns with a new atomization technology that meet the regulatory requirements of the State of California, which imposes the world's most rigorous laws and regulations for paint and coating applications. Subsequently, we developed the LPH Series of HVLP spray guns, which offer performance, low over spray, and high transfer efficiency to satisfy industrial painters around the world, and the W Series of conventional spray guns, which achieve lower over spray and high atomization performance equivalent or superior to that of conventional products by reducing atomizing air pressure (at the gun inlet).

Differences between HVLP and conventional spray guns

HVLP spray guns are designed so that the air cap, fluid nozzle, and main unit construction offer excellent smooth flow characteristics. They can offer high atomization even in the low atomizing air pressure range (air pressure inside air cap of 0.07 MPa or less). Compared to conventional spray guns, they offer high transfer efficiency and reduced over spray. They also help enhance work environments by extending spray booth maintenance intervals and reducing worker exposure to paint contamination.

* Reduces paint consumption by 20 to 30 % (ANEST IWATA data).

How is paint transfer efficiency increased?

- The lower atomizing air pressure allows the paint particles to adhere more readily to the object being sprayed.
- The paint particle size is slightly larger than with conventional spray guns to suppress the over spray associated with very fine particles and to improve transfer efficiency.



ANEST IWATA's design goals

Flat and wide spray pattern

- The flat spray pattern with uniform atomization ensures a fine finish and facilitates multiple coats.
- The wide spray pattern increases work efficiency.

All parts in contact with liquid are made of SUS to allow handling of water-based paints.

- All fluid nipples, fluid nozzles, needles, and body castings are made of high quality stainless steel.

Extensive lineup caters to a wide range of applications

- The lineup includes a wide range of nozzle orifice diameters and high atomization types to allow the selection of the optimal model for a broad range of painting applications.

* Excludes superseded spray guns (and W-61/W-71/W-77).

Manual Spray Gun Selection Guide

Points to note

- Select models from the chart below based on parameters such as Industry/process, Object size, and Paint viscosity.
- If you are unsure which nozzle type to select, 1.3 mm is the standard diameter.
- "★" indicates a recommended model for a particular spray gun body type. (These products offer the greatest versatility and are likely the right choice for those in doubt.)

Differences between HVLP and conventional spray guns

HVLP spray guns are designed so that the air cap, fluid nozzle, and main unit construction offer excellent smooth flow characteristics. They can offer high atomization even in the low atomizing air pressure range (air pressure inside air cap of 0.07 MPa or less).

Compared to conventional spray guns, they offer high transfer efficiency and reduced over spray.

They also help enhance work environments by extending spray booth maintenance intervals and reducing worker exposure to paint contamination.

* Reduces paint consumption by 20 to 30 % (ANEST IWATA data).

How is transfer efficiency increased?

- The lower atomizing air pressure allows the paint particles to adhere more readily to the object being sprayed.
- The paint particle size is slightly larger than with conventional spray guns to suppress the over spray associated with very fine particles and to improve transfer efficiency.

Precautions when using HVLP spray guns

Using HVLP spray guns with an inlet pressure exceeding the recommended conditions indicated in the catalog will cause the spray gun to behave in the same way as a regular spray gun; it will not function as a low pressure device. Increasing atomizing air pressure will gradually eliminate the benefits of using an HVLP spray gun.

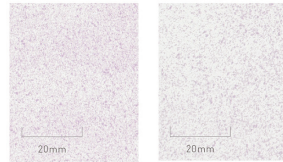

Manually-controlled pressure can be increased for applications like this.

HVLP spray guns indicated by the "◆" symbol use a split nozzle with high atomization efficiency. They can be used as spray guns offering even finer atomization than conventional spray guns by manually increasing atomizing air pressure.

* In this case, the spray gun will no longer be operating in the low pressure range.

Typical applications are listed here. Applications are also provided in the specifications tables for individual products. Refer to both when selecting products.

Spray gun	Type of feed	Pressure feed										Side cup (gravity feed)	Side cup (gravity feed)/Suction feed										Center cup (gravity feed)																										
	Body model	WIDER1				WIDER2				LPH-50		WIDER1								WIDER2		LPH-80		WIDER3	LPH-300		WIDER4				WIDER4L																		
	Remarks	Conventional				HVLP				HVLP		Conventional								HVLP		Conventional		HVLP		Conventional				HVLP																			
Model suffix	-08E2P	-10E2P	-13E2P	-15E2P	L-12G2P	-12G2P	L-10G2P	L-12G2P	L-14G2P	L-2-10G2P	L-2-12G2P	-042G	-062G	-102G	-10E1G/S	-13K1G/S	-13H2G/S	-13H4G/S	-15K1G/S	-15H2G/S	-18N1G/S	L-2-12J2G/S	L-2-14J2G/S	L-2-16J2G/S	-15K1G/S	-15K2G/S	-18K2G/S	-20R1G/S	-20R2G/S	-25W1G/S	-042G	-062G	-082G	-102G	-122G	-10K1	-13H2	-124LV	-144LV	-164LV	-12J2	-13J2	-14J2	-16J2	-18N2	-25W1	-V13J2	-V14J2	-V16J2
Recommended! →			★		★									★			★											★								★							★						
High atomization	✓	✓	✓	✓	✓	✓	✓	✓	✓	✓	✓	✓	✓	✓			✓	✓		✓		◆	◆	◆	✓	✓		✓			✓	✓	✓	✓	✓	✓	◆	◆	◆	✓	✓	✓	✓	✓		◆	◆	◆	
Nozzle orifice (φmm)	0.8	1.0	1.3	1.5	1.2	1.2	1.0	1.2	1.4	1.0	1.2	0.4	0.6	1.0	1.0	1.3	1.3	1.3	1.5	1.5	1.8	1.2	1.4	1.6	1.5	1.5	1.8	2.0	2.0	2.5	0.4	0.6	0.8	1.0	1.2	1.0	1.3	1.2	1.4	1.6	1.2	1.3	1.4	1.6	1.8	2.5	1.3	1.4	1.6
Nozzle shape	Straight	Straight	Straight	Straight	Straight	Straight	Straight	Straight	Straight	Split	Split	Straight	Straight	Straight	Straight	Straight	Straight	Straight	Straight	Straight	Straight	Split	Split	Split	Straight	Straight	Straight	Straight	Straight	Straight	Straight	Straight	Straight	Straight	Straight	Straight	Split	Split	Split	Straight	Straight	Straight	Straight	Straight	Straight	Split	Split	Split	
Industry/process	Automotive line painting	Middle coat	○	○	○	○	○	○	○	○	○																																						
		Top coat	○	○			○	○	○	○	○	○																																					
		Repair/touch-up											○	○	○			○	○					○	○	○							○	○	○	○	○	○	○	○	○	○	○	○	○	○	○	○	○
	Buses/trucks	Middle/Top coat	○				○	○	○	○	○											○																											
		Metal	○	○	○	○	○	○	○	○	○																																						
	Plastic (small size)	Top coat	○				○																○	○	○																								
		Wood/furniture	○	○	○	○	○	○	○	○	○																																						
	Steel frames	Corrosion prevention																																															
		Adhesive																																															
	Object size	Small (up to 60 cm ²)	←→				←→					←→	←→	←→	←→	←→	←→	←→	←→	←→	←→	←→	←→	←→	←→	←→	←→	←→	←→	←→	←→	←→	←→	←→	←→	←→	←→	←→	←→	←→	←→	←→	←→						
Medium (up to 150 cm ²)			←→	←→	←→	←→	←→	←→	←→	←→																																							
Large (over 150 cm ²)																																																	
Paint viscosity (ANEST IWATA cup / NK-2)	Low viscosity (up to 15 sec)	←→				←→	←→	←→	←→	←→	←→	←→	←→	←→	←→	←→	←→	←→	←→	←→	←→	←→	←→	←→	←→	←→	←→	←→	←→	←→	←→	←→	←→	←→	←→	←→	←→	←→	←→	←→	←→	←→							
	Medium viscosity (15 to 25 sec)		←→	←→	←→	←→	←→	←→	←→	←→																																							
	High viscosity (25 to 35 sec)																																																

Model code explanation

Example: WIDER2 L - 2 - 12 G2 P

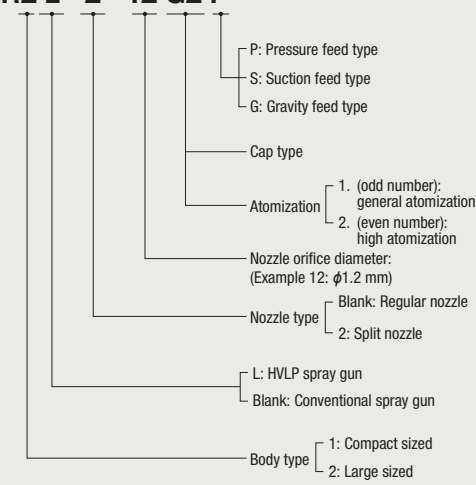

Optional maintenance wrenches are also available for spray guns other than the W-61, W-71, and W-77. Optional parts (nozzles and needle sets) made of more abrasion-resistant materials are available for the WIDER2/ZL pressure feed models for line painting involving highly abrasive paints with high paint flow rates or frequent use.

- Ideal
- Suitable
- ◆ Finer atomization can be achieved by manually adjusting pressure to approximately 0.2 MPa. (In this case, the spray gun will be operating in the conventional spray gun range, not the HVLP spray gun range.)

Please check the appropriate related equipment once again to ensure optimal painting.

Is air flow sufficient?

Compressors can provide air flows of approximately 80 L/min for each 0.75 kW (1 PS). The compressor should have approximately 20 to 30 % larger capacity than that required for the air flow rate of the selected spray gun.

Clean air is essential for painting.

Oil-free compressors do not use lubricating oil in the compression process. Nevertheless, they contain trace amounts of impurities, including atmospheric moisture and oil, oil adhering to parts during manufacture, wear, and plumbing corrosion. Using such compressors may lead to paint defects such as peeling and repulsion. To avoid these problems, carefully check the operating conditions (pressure, flow rate, temperature, environment, and power supply) and select and install the appropriate equipment.

Use spray guns with appropriate air pressures.

Spray guns perform to their full potential only when is used at the pressures specified in the instruction manual. Be sure to install an air regulator or air transformer close to the operator. Adjust clean air to the specified pressure before use.

Note

The values provided in this catalog are obtained using ANEST IWATA test paints. Actual values may vary depending on the paint and conditions used.

WIDER

This is The Newest Spray Gun

Reliable quality and consistency A new model goes from "W" to "WIDER"

The key considerations for industrial painting products are quality and consistency. ANEST IWATA has developed a range of spray guns optimized to support ever diversifying applications and constantly evolving paints. The WIDER1 and WIDER2 models were developed in further pursuit of these key considerations based on the combined experience and expertise accumulated to date since the previous models, W-101 and W-200.



WIDER1

Compact sized spray guns

A conventional type ideal for all kinds of applications, from automotive painting to metal, plastic, wood, and furniture. It is recommended for objects up to around 150 cm² in area.

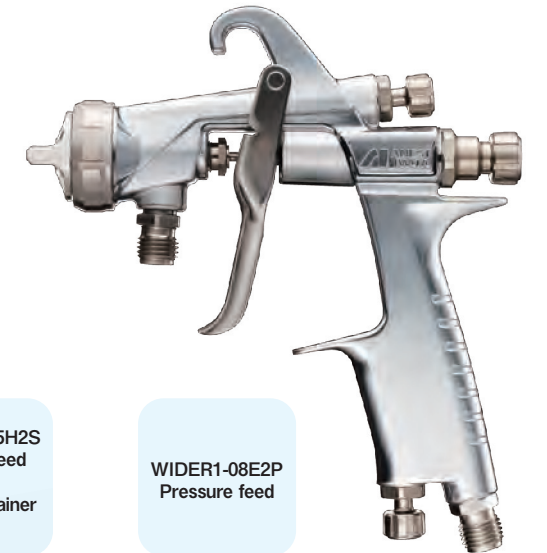

WIDER1-13K1G
Gravity feed
With
PC-400SB-2LF
cup fitted

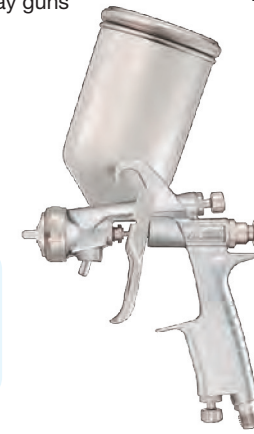

WIDER1-15H2S
Suction feed
With
PC-2 container
fitted



WIDER1-08E2P
Pressure feed

*Paint containers are sold separately.



FEATURE 01 DESIGN

Ergonomic performance-focused design

The application of ergonomic design to individual parts achieves weight savings of 5 g compared to previous models. Knobs feature a tapered design with deep grooves for improved grip and easier fine adjustment. Resin parts incorporated behind the needle valve spring enable smoother paint adjustments. Lastly, a smoother trigger tip design improves controllability for low flow rate painting.



FEATURE 02 MAINTENANCE

New model offering easier maintenance

The new WIDER products are designed for easy maintenance. The cap screw thread pitch has been changed from 1.0 mm to 1.5 mm, allowing tightening in approximately one and a half turns, half of that previously required. The rear of the needle valve has been designed to allow easy attachment and detachment. Straight sections free of screw threads in the air and fluid nipples facilitate joint attachment.

FEATURE 03 FEEL

Pattern adjuster with linear response

With the previous pattern adjuster, turning one revolution gave a pattern width of approximately 45 %; a 1.5-revolution turn gave a pattern width of approximately 80 %; and two revolutions resulted in a fully opened state with a pattern width of approximately 100 %. The newly developed pattern adjuster provides more intuitive linear response adjustments, with one revolution resulting in a pattern width of approximately 35 %; 1.5 revolutions resulting in a pattern width of approximately 50 %; and two revolutions resulting in a pattern width of approximately 70 %.

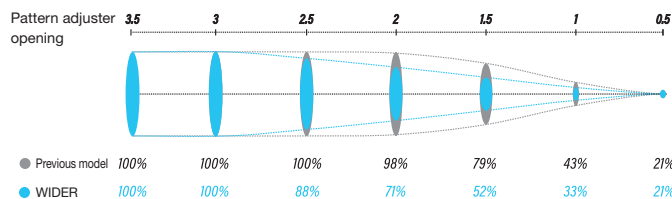

FEATURE 04 REPEATABILITY

Air valve seat set with minimal individual differences

With previous air valve seat sets, the size of the air path opening was a combination of large and small; the positional relationship (i.e., individual differences) when screwed generated differences in air flow rates, with potential impact on paint flow rates and pattern widths. This configuration has been revised in the new WIDER. Larger and more uniform openings achieve minimal individual differences in the air valve seat when screwed in or out for more consistent painting performance.



Real painter's kit

● All-in-one package for immediate use
(Requires separate hose to connect to the pressurized container.)

Real painter's kit 2 WIDER1-S71

- Spray gun WIDER1-15E2P (p. 33)
- Pressurized container PC-18D (p. 34)
- Twin hose (2 m) THU-620 (p. 34)
- Joint PJU-02F × 3, PJU-023F × 1 (p. 34)

Real painter's kit 3 WIDER1-S81

- Spray gun WIDER1-13E2P (p. 33)
- Pressurized container PC-18D (p. 34)
- Twin hose (2 m) THU-620 (p. 34)
- Joint PJU-02F × 3, PJU-023F × 1 (p. 34)

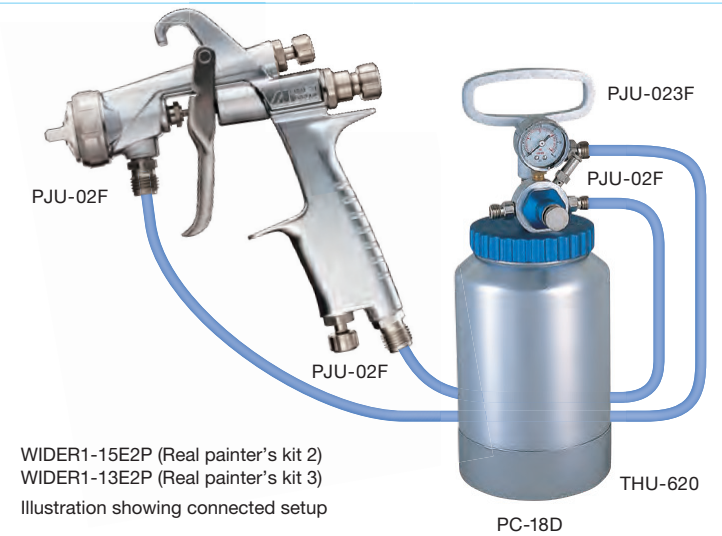

WIDER1-15E2P (Real painter's kit 2)
WIDER1-13E2P (Real painter's kit 3)
Illustration showing connected setup

WIDER1 SPEC

Previous model	Model	Type of feed	Nozzle orifice φmm	Atomizing air pressure MPa	Air consumption L/min	Paint flow rate mL/min	Pattern width mm	Atomization	Air cap model	Mass g
W-101-082P	WIDER1-08E2P	Pressure	0.8	0.29	270	150	190	High atomization	WIDER1-E2P	290
W-101-102P	WIDER1-10E2P		1.0		270	200	220	High atomization	WIDER1-E2P	
W-101-132P	WIDER1-13E2P		1.3		220	200	210	High atomization	WIDER1-E2P	
W-101-152P	WIDER1-15E2P		1.5		220	250	240	High atomization	WIDER1-E2P	
W-101-101S	WIDER1-10E1S	Suction	1.0	0.24	75	85	120	General atomization	WIDER1-E1	290
W-101-131S	WIDER1-13K1S		1.3		145	150	155	General atomization	WIDER1-K1	
W-101-132S	WIDER1-13H2S		1.3		225	150	160	High atomization	WIDER1-H2	
W-101-134S	WIDER1-13H4S		1.3		210	140*	180*	High atomization	WIDER1-H4	
W-101-151S	WIDER1-15K1S	Gravity	1.5	0.24	145	175	170	General atomization	WIDER1-K1	290
W-101-152S	WIDER1-15H2S		1.5		225	170	175	High atomization	WIDER1-H2	
W-101-181S	WIDER1-18N1S		1.8		170	210	170	General atomization	WIDER1-N1	
W-101-101G	WIDER1-10E1G		1.0		75	95	130	General atomization	WIDER1-E1	
W-101-131G	WIDER1-13K1G	Gravity	1.3	0.24	145	160	170	General atomization	WIDER1-K1	290
W-101-132G	WIDER1-13H2G		1.3		225	160	175	High atomization	WIDER1-H2	
W-101-134G	WIDER1-13H4G		1.3		210	155*	205*	High atomization	WIDER1-H4	
W-101-151G	WIDER1-15K1G		1.5		145	200	180	General atomization	WIDER1-K1	
W-101-152G	WIDER1-15H2G	Gravity	1.5	0.24	225	190	190	High atomization	WIDER1-H2	290
W-101-181G	WIDER1-18N1G		1.8		170	240	190	General atomization	WIDER1-N1	

● The spray distance is 200 mm for all models. ● Paint viscosity: 20 sec / NK-2 (12 sec / NK-2 where marked "") ● Nipple size for all models: Fluid nipple G1/4 (male), air nipple G1/4 (male)
● Refer to the details on related equipment on p. 4 when selecting the required compressor.

WIDER2

Large sized spray gun

A conventional type ideal for all kinds of applications, from automotive painting to metal, plastic, wood, and furniture. It is recommended for objects with an area of 150 cm² or more.

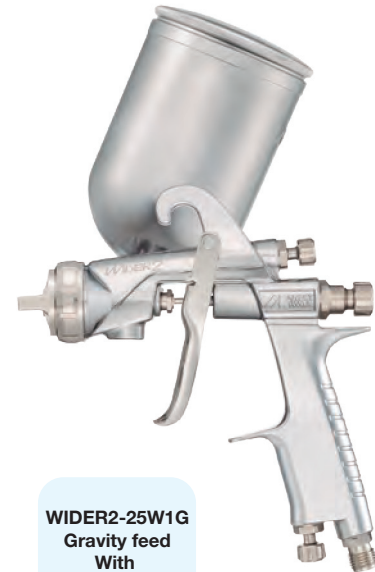

WIDER2-25W1G
Gravity feed
With
PC-4 cup fitted



WIDER2-20R2S
Suction feed
With
PCL-10B-3
container fitted

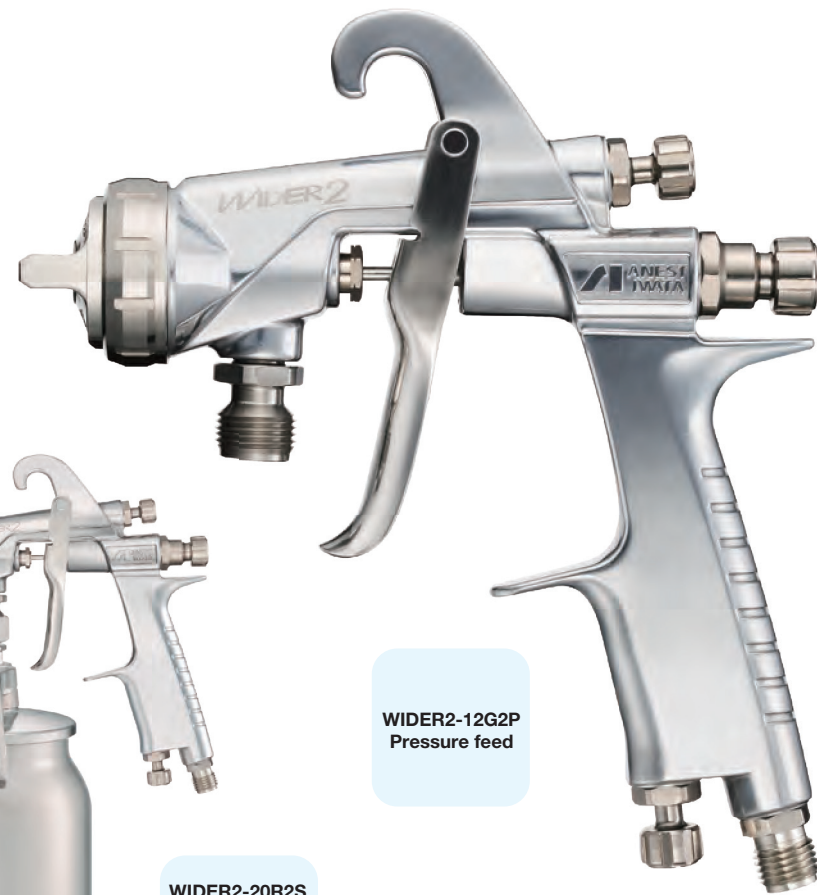

WIDER2-12G2P
Pressure feed

*Paint containers are sold separately.

WIDER1L

WIDER2L

HVLP

Compact/large sized HVLP spray guns

High transfer efficiency & optimal atomization in low atomizing air pressure range

Reducing paint consumption and volatile organic compound (VOC) emissions is a major issue for painting applications. These spray guns feature proprietary dedicated air caps, dedicated nozzles, and a spray gun body mechanism to ensure high transfer efficiency and optimal atomization in the low atomizing air pressure range.

* Reduces paint consumption by 20 to 30 % (ANEST IWATA data).

Reducing over spray extends spray booth maintenance intervals and reduces worker paint exposure, enhancing work environments.

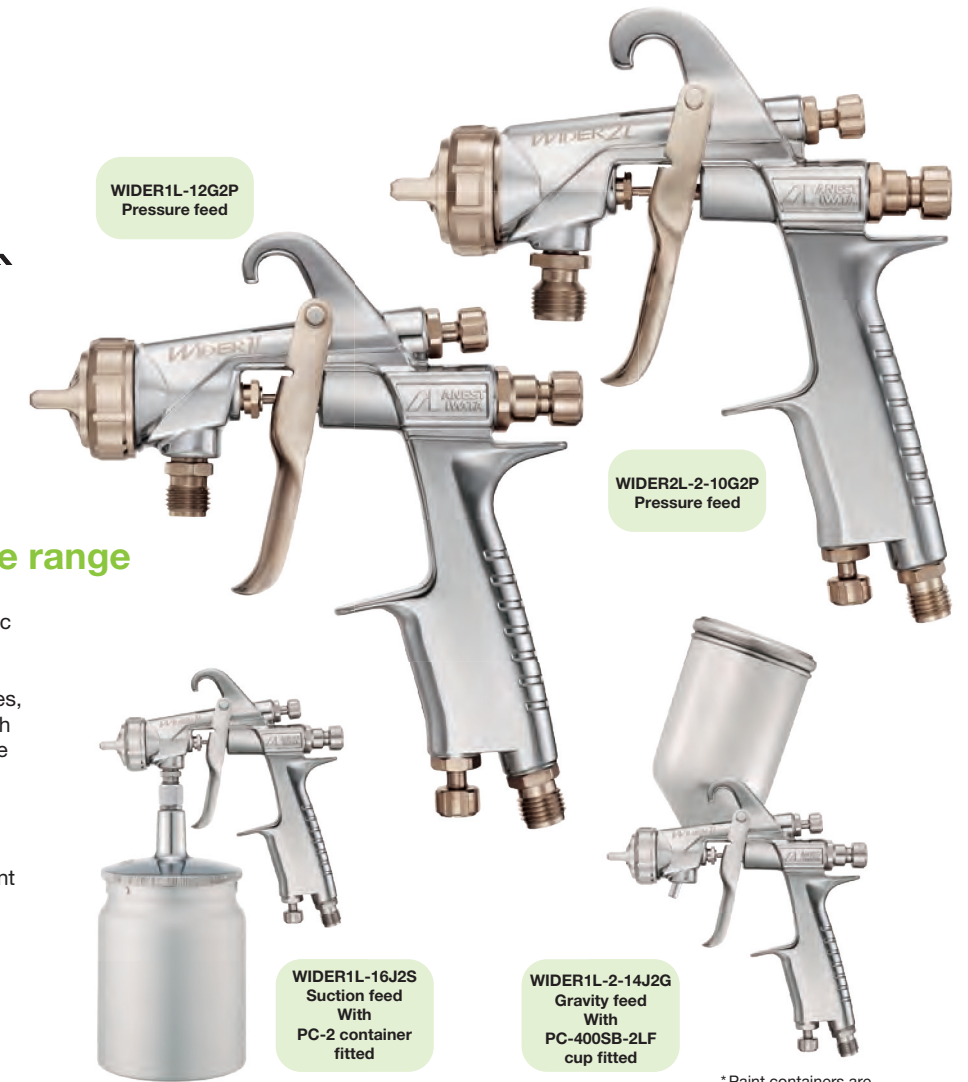

WIDER1L-12G2P
Pressure feed

WIDER2L-2-10G2P
Pressure feed

WIDER1L-16J2S
Suction feed
With
PC-2 container
fitted

WIDER1L-2-14J2G
Gravity feed
With
PC-400SB-2LF
cup fitted

*Paint containers are sold separately.

What are HVLP spray guns?

Spray guns capable of operating with an air pressure inside air cap not exceeding 0.069 MPa are referred to as HVLP (High Volume Low Pressure) spray guns. This is defined by the US state of California (South Coast Air Quality Management District), which has the most stringent environmental regulations. (Regular spray guns typically have an air pressure inside air cap of 0.14 to 0.20 MPa).

WIDER2 SPEC

Previous model	Model	Type of feed	Nozzle orifice φmm	Atomizing air pressure MPa	Air consumption L/min	Paint flow rate mL/min	Pattern width mm	Atomization	Air cap model	Mass g
W-200-122P	WIDER2-12G2P	Pressure	1.2	0.29	500	500	400	High atomization	WIDER2-G2P	375
W-200-151S	WIDER2-15K1S		1.5		200	240	210	General atomization	WIDER2-K1	
W-200-152S	WIDER2-15K2S		1.5		330	240	290	High atomization	WIDER2-K2	
W-200-182S	WIDER2-18K2S		1.8		330	290	340	High atomization	WIDER2-K2	375
W-200-201S	WIDER2-20R1S	Suction	2.0	0.29	260	350	260	General atomization	WIDER2-R1	
W-200-202S	WIDER2-20R2S		2.0		360	350	290	High atomization	WIDER2-R2	
W-200-251S	WIDER2-25W1S		2.5		360	440	280	General atomization	WIDER2-W1	
W-200-151G	WIDER2-15K1G		1.5		200	270	220	General atomization	WIDER2-K1	
W-200-152G	WIDER2-15K2G		1.5		330	270	320	High atomization	WIDER2-K2	
W-200-182G	WIDER2-18K2G		1.8		330	320	380	High atomization	WIDER2-K2	375
W-200-201G	WIDER2-20R1G	Gravity	2.0	0.29	260	410	280	General atomization	WIDER2-R1	
W-200-202G	WIDER2-20R2G		2.0		360	410	320	High atomization	WIDER2-R2	
W-200-251G	WIDER2-25W1G		2.5		360	510	310	General atomization	WIDER2-W1	

● The spray distance is 250 mm for all models. ● Paint viscosity: 20 sec / NK-2 ● Nipple size for all models: Fluid nipple G3/8 (male), air nipple G1/4 (male)
● Refer to the details on related equipment on p. 4 when selecting the required compressor.

WIDER1L SPEC

Previous model	Model	Type of feed	Nozzle orifice φmm	Atomizing air pressure MPa	Air pressure inside air cap MPa	Air consumption L/min	Paint flow rate mL/min	Pattern width mm	Atomization	Air cap model	Mass g
LPH-101-122P	WIDER1L-12G2P	Pressure	1.2	0.34	0.069	530	350	270	High atomization	WIDER1L-G2	
LPH-101-124LVS	WIDER1L-2-12J2S		1.2			200	60	170	High atomization	WIDER1L-2-J2	290
LPH-101-144LVS	WIDER1L-2-14J2S	Suction	1.4	0.10	0.049	200	80	180	High atomization	WIDER1L-2-J2	
LPH-101-164LVS	WIDER1L-2-16J2S		1.6			200	95	190	High atomization	WIDER1L-2-J2	
LPH-101-124LVG	WIDER1L-2-12J2G		1.2			200	80	200	High atomization	WIDER1L-2-J2	
LPH-101-144LVG	WIDER1L-2-14J2G	Gravity	1.4	0.10	0.049	200	130 ^{*1}	220 ^{*1}	High atomization	WIDER1L-2-J2	290
LPH-101-164LVG	WIDER1L-2-16J2G		1.6	0.13	0.069	240	100 ^{*1}	220 ^{*1}	High atomization	WIDER1L-2-J2	

● The spray distance is 200 mm for all models. ● Paint viscosity: 20 sec / NK-2 ● Nipple size for all models: Fluid nipple G1/4 (male), air nipple G1/4 (male) *1 Paint viscosity: 12 sec / NK-2
● Refer to the details on related equipment on p. 4 when selecting the required compressor.

WIDER2L SPEC

Previous model	Model	Type of feed	Nozzle orifice φmm	Atomizing air pressure MPa	Air pressure inside air cap MPa	Air consumption L/min	Paint flow rate mL/min	Pattern width mm	Atomization	Air cap model	Mass g
New Model	WIDER2L-10G2P		1.0			470	300	250	High atomization	WIDER2L-G2	
LPH-200-122P	WIDER2L-12G2P		1.2			470	500	300	High atomization	WIDER2L-G2	
New Model	WIDER2L-14G2P	Pressure	1.4	0.20	0.069	470	500	300	High atomization	WIDER2L-G2	375
New Model	WIDER2L-2-10G2P		1.0			430	100	330	High atomization	WIDER2L-2-G2	
	WIDER2L-2-12G2P		1.2			430	130	350	High atomization	WIDER2L-2-G2	

● The spray distance is 200 mm for all models. ● Paint viscosity: 20 sec / NK-2 ● Nipple size for all models: Fluid nipple G3/8 (male), air nipple G1/4 (male)
● Refer to the details on related equipment on p. 4 when selecting the required compressor.

WIDER3

Compact sized spray gun (center cup)

Twenty years after the W-300 was first launched, the model has undergone a full model upgrade. The reimagined WIDER3 features a complete update of features and design for even greater ease of use.



■ Features

* Improved handling performance

Ergonomic design emphasizes performance, while trigger design improves controllability for low flow rate painting.

* Ease of maintenance

The cap screw thread pitch has been changed to allow removal in approximately half the time. A groove behind the needle valve allows easy attachment and detachment.

* Consistent painting with minimal individual variations

The air valve construction has been revised to increase and standardize the opening size to minimize pressure losses and reduce variations dependent on the screw position.

* Easier and more intuitive pattern adjustment

The new design ensures linear adjustments of the opening of the pattern adjuster.

* Unchanged ease of cleaning and corrosion resistance

The body features twilight chrome plating.

* While the basic performance of the caps, nozzles, and needles remain unchanged, the parts are not interchangeable.

[Compact sized center cup spray gun with same size as WIDER1]

Compared to side cup types, such as the WIDER1, center cup spray guns offer the following two advantages:



① Compatibility with high viscosity paint

The paint route from cup to nozzle is nearly straight. The paint route inside the center cup is large. This allows compatibility with high viscosity paints, even when using the same nozzle orifice diameter.

② Excellent weight balance reduces fatigue

The cup is located over the spray gun's center of gravity so that the weight of the paint acts vertically on the operator's hand. This also makes it easier for left-handed operators to check painted surfaces while spraying.

■ Specifications

Previous model	Model	Type of feed	Fluid nozzle		Atomizing air pressure MPa	Paint flow rate mL/min	Pattern width mm	Air consumption L/min	Air cap model	Mass g
			Orifice φmm	Shape						
W-300-101G	WIDER3-10K1	Gravity	1.0	Straight	0.25	120	130	145	WIDER1-K1	315
W-300-132G	WIDER3-13H2		1.3							

- The spray distance is 200 mm for all models. ● Paint viscosity: 20 sec / NK-2 ● Nipple size for all models: Fluid nipple G1/4 (female), air nipple G1/4 (male)
- Use the PC-G600P-2 (600 mL), PC-G400P-2 (400 mL), or PC-G2P-2 (200 mL) paint cups.
- Refer to the details on related equipment on p. 4 when selecting the required compressor.

WIDER4

Large sized spray gun (center cup)



It has been 23 years since the launch of the W-400/LPH-400. These spray guns have now undergone a long-awaited full model refresh. Reemerging as the WIDER4 and the low pressure WIDER4L, they feature completely new functionality, sophisticated design, and are easier to use than ever before.

They are recommended for painting metal, plastic, and wooden furniture and for applying corrosion inhibitors to steel frames. They are also ideal for use with water-based and high-solid paints.

■ Features

* Improved handling performance

Ergonomic design emphasizes performance, while trigger design improves controllability for low flow rate painting.

* Ease of maintenance

The cap screw thread pitch has been changed to allow removal in approximately half the time. A groove behind the needle valve allows easy attachment and detachment.

* Consistent painting with minimal individual differences and variations between lots

The air valve construction has been revised to increase and standardize the opening size to minimize pressure losses and reduce variations dependent on the screw position.

* Easier and more intuitive pattern adjustment

The new design ensures linear adjustments of the opening of the pattern adjuster.

* The basic performance of the caps, nozzles, and needles remain unchanged.

■ Specifications

Previous model	Model	Type of feed	Fluid nozzle		Atomizing air pressure MPa	Air pressure inside air cap MPa	Paint flow rate mL/min	Air consumption L/min	Pattern width mm	Air cap model	Mass g
			Orifice φmm	Shape							
W-400-122G	WIDER4-12J2	Gravity	1.2	Straight	0.20	140	280	280	230	WIDER4-J2	355
W-400-132G	WIDER4-13J2		1.3								
W-400-142G	WIDER4-14J2		1.4								
W-400-162G	WIDER4-16J2		1.6								
W-400-182G	WIDER4-18N2	Gravity	1.8	Split	0.11	0.07	320	290	280	WIDER4-N2	355
W-400-251G	WIDER4-25W1		2.5								
LPH-400-134LV	WIDER4L-V13J2		1.3								
LPH-400-144LV	WIDER4L-V14J2	Gravity	1.4	Split	0.11	0.07	130	270	290	WIDER4L-J2	355
LPH-400-164LV	WIDER4L-V16J2		1.6								

- The spray distance is 200 mm for the WIDER4 and 250 mm for the WIDER4L. ● Paint viscosity: 20 sec / NK-2 ● Nipple size for all models: Fluid nipple G1/4 (female), air nipple G1/4 (male)
- The PCG-6P-M paint cup for the previous model is not compatible. Use the PC-G600P-2 (600 mL) or PC-G400P-2 (400 mL) cups.
- Refer to the details on related equipment on p. 4 when selecting the required compressor.

[Ergonomic design with focus on performance]

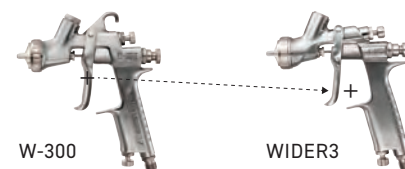

Overall weight has been reduced by 5 g compared to previous models. The grip has been lengthened to bring the center of gravity closer to the hand position. This greatly improves handling and reduces fatigue, which is expected to improve work efficiency.

* The center of gravity indicated in the photographs is for illustrative purposes.

[Ergonomic design with focus on performance]

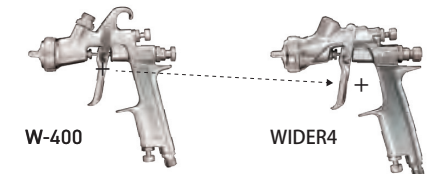

Overall weight has been reduced by 25 g compared to previous models. Overall length has been reduced and the grip has been lengthened to bring the center of gravity closer to the hand position. This greatly improves handling and reduces fatigue, which is expected to improve work efficiency.

* The center of gravity indicated in the photographs is for illustrative purposes.

WS-200

Pressure feed large sized spray guns

These flagship pressure feed spray gun models are optimally tuned for use with water-based and environmentally-friendly paints. The models incorporate a 100 % in-house design right down to the smallest parts.

Features

Consistent spray patterns even at lower atomizing air pressures

A dedicated baffle ring improves the stability of air patterns. Patterns remain stable even under challenging conditions such as lower atomizing air pressure to minimize paint application defects. The baffle ring is readily detached for easy cleaning.



Improved handling

The body, grip, trigger, and various knobs are designed with ergonomics in mind. The stainless steel trigger is fitted with a resin pad for smooth, responsive operation. The position of the center of gravity, a key design consideration, minimize fatigue over extended periods of use.

Improved durability and ease of cleaning

The models have forged bodies for greater body strength than regular spray guns with die-cast bodies. They are also chrome-plated for ease of cleaning.



Easier and more intuitive pattern adjustment

The new design ensures linear adjustments of the opening of the pattern adjuster.

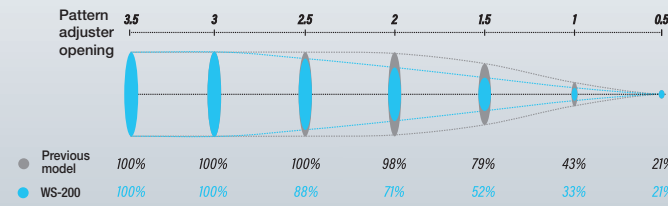

For water-based paints WS-200SP V-slit nozzle



For general and eco-friendly paints WS-200FT Straight nozzle

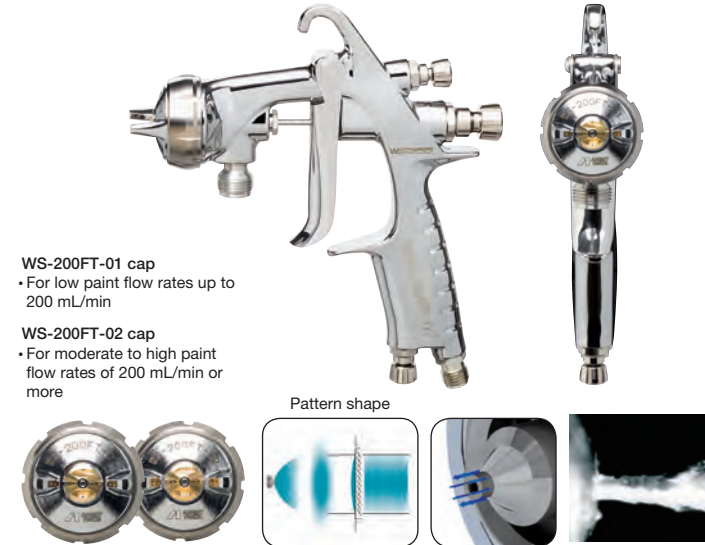

WS-200FT-01 cap
• For low paint flow rates up to 200 mL/min

WS-200FT-02 cap
• For moderate to high paint flow rates of 200 mL/min or more

Split nozzle

This technology achieves high atomization by cutting a slit in the nozzle, which allows air to flow through as if cutting the paint. High atomization efficiency allows paint atomization even with low atomizing air pressure and low air consumption.

- High atomization makes it easier to achieve a high quality paint finish.
- Increased transfer efficiency results in lower over spray and lower paint consumption.

Model	Nozzle orifice ϕ mm	Air cap model	Atomizing air pressure MPa	Paint flow rate mL/min	Air consumption L/min	Pattern width mm	Mass g
WS-200SP-0801	0.8	WS-200SP-01		200	435	210	
WS-200SP-1001	1.0	WS-200SP-01	0.25	250	435	230	395
WS-200SP-1201	1.2	WS-200SP-01		300	435	240	
WS-200FT-0801	0.8	WS-200FT-01		200	380	240	
WS-200FT-1001	1.0	WS-200FT-01	0.25	200	380	220	395
WS-200FT-1201	1.2	WS-200FT-01		200	380	210	
WS-200FT-0802	0.8	WS-200FT-02		200	475	215	
WS-200FT-1002	1.0	WS-200FT-02	0.30	250	475	250	395
WS-200FT-1202	1.2	WS-200FT-02		300	475	255	

● The spray distance is 150 mm for all models. ● Paint viscosity: all models: 20 sec / NK-2
● Nipple size for all models: Fluid nipple G3/8 (male), air nipple G1/4 (male)
● Refer to the details on related equipment on p. 4 when selecting the required compressor.

Ultra compact sized spray guns

LPH-50/W-50 Specifically for top coat spraying of small surfaces

- Reduced tip scatter reduces blackening.
- Allows atomization even with low pressure painting.
- Reduces paint adherence to air cap.

Ultra compact sized HVLP spray gun
LPH-50-102G
Gravity feed
With PC-51 cup fitted

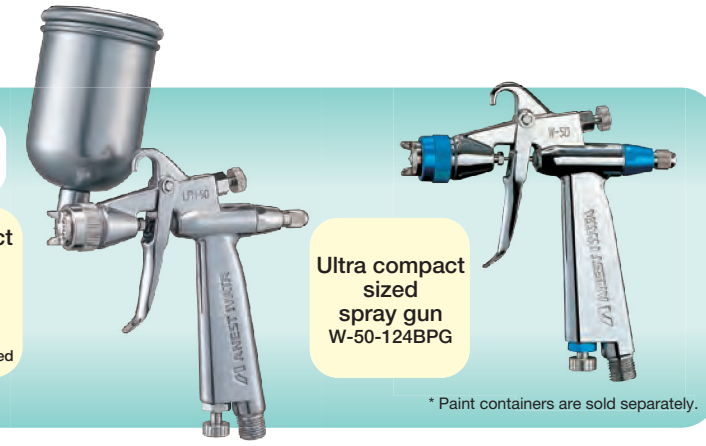

Ultra compact sized spray gun
W-50-124BPG

* Paint containers are sold separately.

Model	Type of feed	Nozzle orifice ϕ mm	Atomizing air pressure MPa	Air pressure inside air cap MPa	Air consumption L/min	Paint flow rate mL/min	Pattern width mm	High atomization	Air cap model	Compressor requirements kW	Mass g	Applications
LPH-50-042G		0.4			50	8	40	✓	E2	0.2 to 0.75		
LPH-50-062G	Gravity	0.6	0.09	0.07	50	25	60	✓	E2	0.2 to 0.75	220	For automotive repairs (touch-up, fade-out painting)
LPH-50-102G		1.0			50	55	100	✓	E2	0.2 to 0.75		
W-50-124BPG		1.2	0.15	—	65	85	160	✓	50	0.4	185	Dedicated automatic repair paint

● The spray distance is 100 mm for the LPH-50-042G, 150 mm for the -062G/-102G, and 150 mm for the 124BPG. ● Paint viscosity: all models: 12 sec / NK-2
● Nipple size for all models: Fluid nipple G1/4 (male), air nipple G1/4 (male)
● Refer to the details on related equipment on p. 4 when selecting the required compressor.

Round spraying gun

RG-3L

Ideal for paint and dye spraying on plastic models, fabrics, arts and crafts, and DIY, etc. Can also be used for repairing small scratches on vehicles.

RG-3L
With PC-51 cup fitted



* Paint containers are sold separately.

Previous model	Model	Type of feed	Nozzle orifice ϕ mm	Atomizing air pressure MPa	Air consumption L/min	Paint flow rate mL/min	Pattern width mm	Compressor requirements kW	Standard paint container	Mass g
RG-2-1	RG-3L-1 *RG-3L1-1		0.4		30	15	25	0.2 to 0.75	Gravity feed cup PC-51 (220 mL) PC-61 (130 mL)	180
RG-2-2	RG-3L-2 *RG-3L1-2	Gravity	0.6	0.24	30	35	35	0.2 to 0.75		
RG-2-3	RG-3L-3 *RG-3L1-3		1.0		50	80	35	0.2 to 0.75		

● The spray distance is 200 mm for all models. ● Paint viscosity for the RG-3L-2/-3L1-2/-3L1-3: 12 sec / NK-2
● Nipple size for all models: Fluid nipple G1/4 (male), air nipple G1/4 (male) * With air flow adjuster

HVLP center cup spray guns

LPH-80/LPH-300

Ideally balanced center of gravity

The paint container is located directly above the spray gun for optimal balance and optimal grip/handling.

Flat thin-coat pattern with good mist distribution

Achieves a uniform finish even with water-based and high-solid paints that traditionally caused atomization issues.

Eco-friendly spray gun

The LPH-300 has a high transfer efficiency with low scatter, making it an eco-friendly low air consumption HVLP spray gun.

New fluid nozzle construction (Patented)

LPH-80 HVLP ultra compact sized spray gun (For spot spraying of small items or automotive repairs)

LPH-300 HVLP compact sized spray gun (For painting metal and plastic and automotive repairs)

HVLP ultra compact sized center cup spray gun
LPH-80
Gravity feed
With PCG-2D-1 cup fitted

HVLP compact sized center cup spray gun
LPH-300-144LV
Gravity feed
With PCG-2P-2 cup fitted

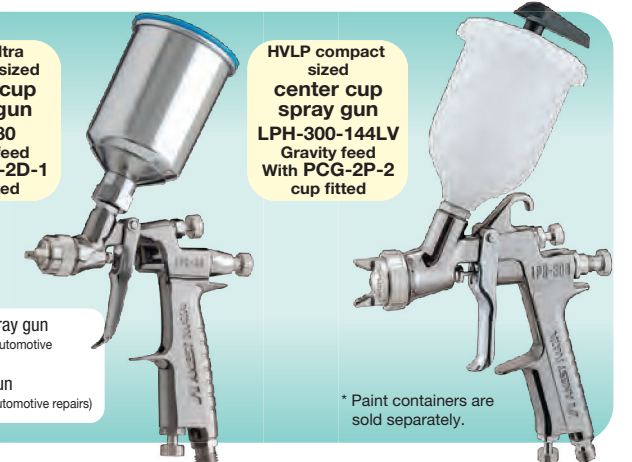

* Paint containers are sold separately.

Model	Type of feed	Nozzle orifice ϕ mm	Atomizing air pressure MPa	Air pressure inside air cap MPa	Air consumption L/min	Paint flow rate mL/min	Pattern width mm	High atomization	General atomization	Air cap model	Compressor requirements kW	Mass g	Applications
LPH-80-042G		0.4			50	8	40	✓		E2	0.2 to 0.75		
LPH-80-062G		0.6			50	25	60	✓		E2	0.2 to 0.75		
LPH-80-082G		0.8	0.09	0.07	50	40	80	✓		E2	0.2 to 0.75		
LPH-80-102G		1.0			50	55	100	✓		E2	0.2 to 0.75		
LPH-80-122G	Gravity	1.2			50	80	120	✓		E2	0.2 to 0.75	205	Automotive repairs Spot spraying on small items
LPH-80-044G		0.4			60	10	55	✓		E4	0.2 to 0.75		
LPH-80-064G		0.6			60	30	80	✓		E4	0.2 to 0.75		
LPH-80-084G		0.8	0.10	0.07	60	45	100	✓		E4	0.2 to 0.75		
LPH-80-104G		1.0			60	60	130	✓		E4	0.2 to 0.75		
LPH-80-124G		1.2			60	75	140	✓		E4	0.2 to 0.75		
LPH-300-124LV	Gravity	1.2		0.05	200	90*	210	✓		LV4	1.5 to 2.2		
LPH-300-144LV		1.4			200	130*	230	✓		LV4	1.5 to 2.2	320	Specifically for automotive repairs (touch-up to block painting)
LPH-300-164LV		1.6	0.13	0.07	240	110	230	✓		LV4	1.5 to 2.2		

● The spray distance is 100 mm for the LPH-80-042G/-044G/-062G/-064G, 150 mm for the -082G/-084G/-102G/-104G/-122G/-124G, and 300 mm for the LPH-300.
● Paint viscosity: 20 sec / NK-2 (12 sec / NK-2 where marked *) ● The nipple size are as follows: LPH-80: Fluid nipple G1/8 (female), air nipple G1/4 (male); LPH-300: Fluid nipple G1/4 (male), air nipple G1/4 (male) ● Refer to the details on related equipment on p. 4 when selecting the required compressor.

Compact/medium sized spray guns

W-61/W-71/W-77

● Please note that orders for the W-71, -61, and -77 spray guns may take some time.

W-71-1S
Suction feed
With
PCL-10B-2
container fitted



W-61-3G
Gravity feed
With
PC-4S
cup fitted



W-77-02
Pressure feed



◀ Model code explanation ▶

Example: W-77-21G

Type of feed: G: Gravity feed type, S: Suction feed type
1/2/3: Conventional, 11/21/31: For high quality painting, 0 (zero): For mass production painting
Body type: W-71, W-61: Compact sized spray guns, W-77: Medium sized spray guns

* Paint containers are sold separately.

Model	Type of feed	Nozzle orifice φmm	Atomizing air pressure MPa	Air consumption L/min	Paint flow rate mL/min	Pattern width mm	Compressor requirements kW	Mass g	Standard paint container
W-61-0	Pressure	0.8	0.34	200	200	190	1.5		Pressurized paint tanks and diaphragm paint pumps
W-61-1S		1.0		75	95	100	0.4		Container
W-61-2S	Suction	1.3		85	135	135	0.4		PC-1S (1,000 mL), PCL-10B-2 (1,000 mL)
W-61-3S		1.5	0.29	150	160	185	0.75	445	PC-2 (600 mL), PCL-7B-2 (700 mL)
W-61-1G		1.0		75	110	120	0.4		Side cup
W-61-2G	Gravity	1.3		85	155	155	0.4		PC-4S (400 mL), PC-51 (220 mL) Stainless steel
W-61-3G		1.5		150	190	220	0.75		PC-5 (250 mL), PC-61 (130 mL) Stainless steel
W-71-0		0.8	0.34	240	200	190	1.5		Pressurized paint tanks and diaphragm paint pumps
W-71-02	Pressure	1.0		230	300	265	1.5		
W-71-1S		1.0		75	95	100	0.4		Container
W-71-2S		1.3		85	135	135	0.4		PC-1S (1,000 mL)
W-71-3S	Suction	1.5		165	180	170	0.75		PC-2 (600 mL), PCL-10B-2 (1,000 mL)
W-71-21S		1.3	0.29	195	140	155	1.5	475	PC-3 (400 mL), PCL-7B-2 (700 mL)
W-71-31S		1.5		230	170	170	1.5		
W-71-4S		1.8		230	195	195	1.5		
W-71-1G		1.0		75	110	120	0.4		Side cup
W-71-2G	Gravity	1.3		85	155	155	0.4		PC-4S (400 mL), PC-5 (250 mL)
W-71-3G		1.5		165	210	185	0.75		PCG-6P-2 (600 mL)
W-71-21G		1.3		195	160	165	1.5		PC-51 (220 mL) (stainless steel)
W-71-31G		1.5		230	190	185	1.5		PC-61 (130 mL) (stainless steel)
W-71-4G		1.8		230	220	220	1.5		PC-150SB-2LF, PC-400SB-2LF, PC-250SB-2LF
W-77-0	Pressure	1.2		430	480	445	2.2 to 3.7		Pressurized paint tanks and diaphragm paint pumps
W-77-02		1.2		420	480	400	2.2 to 3.7		
W-77-1S		1.5		180	255	210	0.75 to 1.5		Container
W-77-11S		1.5		290	255	260	1.5 to 2.2		PC-1 (1,000 mL)
W-77-12S	Suction	1.5		370	255	230	2.2 to 3.7		PCL-10B-3 (1,000 mL), PCL-7B-3 (700 mL)
W-77-2S		2.0		250	345	255	1.5		PC-19R (1,000 mL)
W-77-21S		2.0	0.34	340	350	270	1.5 to 2.2	550	
W-77-3S		2.5		325	435	280	1.5 to 2.2		
W-77-1G		1.5		180	285	230	0.75 to 1.5		Side cup
W-77-11G	Gravity	1.5		290	285	290	1.5 to 2.2		PCG-6P-3 (600 mL)
W-77-12G		1.5		370	285	255	2.2 to 3.7		PC-4 (400 mL)
W-77-2G		2.0		250	390	290	1.5		
W-77-21G		2.0		340	390	335	1.5 to 2.2		
W-77-3G		2.5		325	485	330	1.5 to 2.2		

● The spray distance is 200 mm for the W-61/W-71 and 250 mm for the W-77. ● Paint viscosity: 20 sec / NK-2
● The nipple size are as follows: W-61/W-71: Fluid nipple G1/4 (male), air nipple G1/4 (male); W-77: Fluid nipple G3/8 (male), air nipple G1/4 (male)
● Refer to the details on related equipment on p. 4 when selecting the required compressor.

Long extension spray gun

LW1

Ideal for applications when spraying large areas on objects that can be rotated. Spray guns designed for painting hard-to-reach locations or inside pipes.

◀ Model code explanation ▶
Example: LW1-10E1-4530

Extension length: 300 mm
Bend angle: 45°
Nozzle orifice: 10 = φ1.0 mm
18 = φ1.8 mm
Long WIDER1

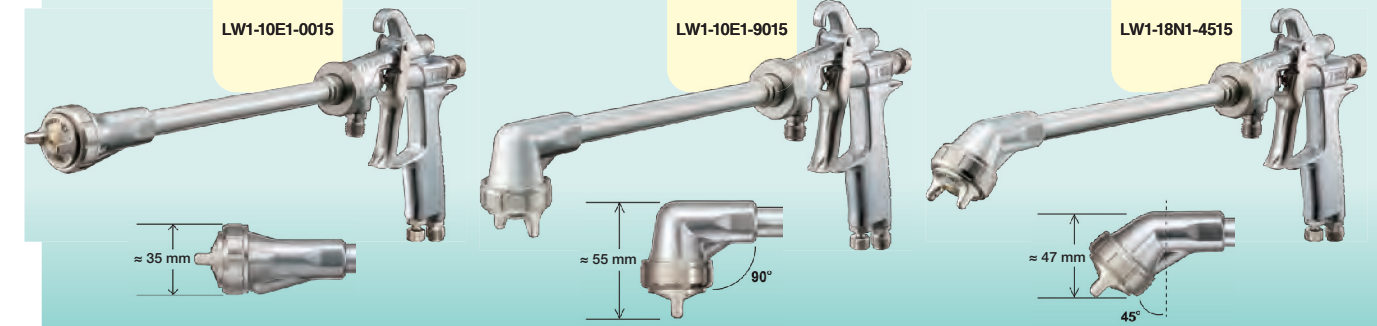

Previous model	Type of feed	Nozzle orifice φmm	Air cap model	Type of pattern	Atomizing air pressure MPa	Paint flow rate mL/min	Extension bend angle °	Extension length mm	Air consumption L/min	Pattern width mm	Mass g
LW-10B-0015	LW1-10E1-0015							150			450
LW-10B-0030	LW1-10E1-0030						0	300			500
LW-10B-0050	LW1-10E1-0050							500			570
LW-10B-4515	LW1-10E1-4515							150			450
LW-10B-4530	LW1-10E1-4530	1.0	E1		0.29	150	45	300	90	175	500
LW-10B-4550	LW1-10E1-4550							500			570
LW-10B-9015	LW1-10E1-9015							150			450
LW-10B-9030	LW1-10E1-9030						90	300			500
LW-10B-9050	LW1-10E1-9050			Flat spraying only				500			570
LW-18B-0015	LW1-18N1-0015							150			450
LW-18B-0030	LW1-18N1-0030						0	300			500
LW-18B-0050	LW1-18N1-0050							500			570
LW-18B-4515	LW1-18N1-4515							150			450
LW-18B-4530	LW1-18N1-4530	1.8	N1		0.34	250	45	300	210	185	500
LW-18B-4550	LW1-18N1-4550							500			570
LW-18B-9015	LW1-18N1-9015							150			450
LW-18B-9030	LW1-18N1-9030						90	300			500
LW-18B-9050	LW1-18N1-9050							500			570

● The spray distance is 200 mm for the LW1-10E1 and 250 mm for the LW1-18N1. ● Paint viscosity: 20 sec / NK-2 ● Nipple size for all models: Fluid nipple G1/4 (male), air nipple G1/4 (male)
● Refer to the details on related equipment on p. 4 when selecting the required compressor. * All models are pressure feed types.

Internal coating spray guns RN1-A/RW1-A

These products are capable of spraying through a full 360°; ideal for applications requiring interior painting of objects that can't be rotated.

● Maximum tip external diameter 10 mm (internal atomization type)

RN1 Rod narrow

RN1-A

Scope Pipe length: 75 mm to 1,500 mm
Pattern nozzle: 120° to 180°

Specifications that can be customized:
Auto/manual, internal/external atomization, pipe length, 360° directional spraying (disk ring pattern)

● Maximum tip external diameter 20 mm (external atomization type)

RW1 Rod wide

RW1-A

Scope Pipe length: 150 mm/300 mm/500 mm
Pattern angle: 150°/180°

Specifications that can be customized:
Auto/manual, internal/external atomization, pipe length, 360° directional spraying (disk ring pattern)

Products can be specified to suit your pipe length and pattern angle requirements. Please feel free to inquire for more information.

HW2

High Viscosity WIDER

High viscosity spray guns

HW-2001/-2003

Capable of ejecting even high viscosity fluids, these spray guns incorporate a simple pressure feed system to eliminate the need for liquid pumps or hoses; recommended for FRP, adhesives, corrosion inhibitors, and marine paints (with viscosity up to 100 mPa-s).

* Paint containers are sold separately.

HW-2001-25
With
PC-19B
pressurized
container fitted



Stainless steel nozzle and needle. Can be used even with water-based adhesives.

W-2003
With
PC-19B
pressurized
container fitted



Previous model	Model	Atomization	Nozzle orifice φmm	Atomizing air pressure MPa	AC: Air consumption (L/min) PW: Pattern width (mm)			
W-2001-1	HW-2001-25PC	Internal mixing	2.5	0.29	Standard HW-2001 caps (two types included)			
	HW-2001-25 (spray gun only)		2.5		25W cap	10W cap		
W-2001-2	HW-2001-30PC	Internal mixing	3.0	0.29	AC	170	AC	100
	HW-2001-30 (spray gun only)		3.0		PW	250 to 400	PW	100 to 250
W-2003	HW-2003-20PC	External mixing	2.0	0.29	AC	270	PW	300 to 400
	HW-2003-20 (spray gun only)		2.0					

- All models are pressure feed types.
- HW spray guns are compatible with the PC-19B only.
- Sets contain spray gun and a pressurized container (PC-19B).
- The HW-2003-20 spray distance is 200 to 300 mm.
- Nipple size for all models: Fluid nipple M16 x 1 (female), air nipple G1/4 (male)
- Refer to the details on related equipment on p. 4 when selecting the required compressor.
- Paint viscosity: 40 sec / NK-2

Disheveled pattern spray gun SGD-71

This spray gun uses a specially configured air cap to produce tangled thread-like pattern or pearskin-like dot pattern. Ideal for use with artistic wood products and fabrics

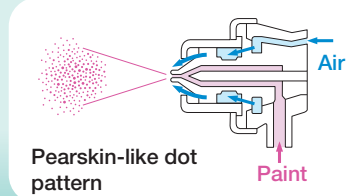
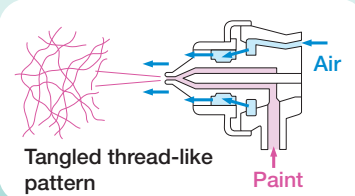

Model	Type of feed	Nozzle orifice φmm	Atomizing air pressure MPa	Air consumption L/min	Paint flow rate mL/min	Compressor requirements kW	Standard paint container	Mass g
SGD-71	Pressure	0.7	0.2	75	80	0.4	Pressurized container PC-17R (400 mL)	1,000

Zceramic

Spray guns for use with abrasive paint

Features carbide components in contact with fluids to ensure excellent wear resistance.

ZP2-A/ZP2-H



ZP2-A
Large sized
automatic
spray gun

* Photo depicts previous model.



ZP2-H
Large sized
manual
spray gun

	Model	Type of feed	Nozzle orifice φmm	Atomizing air pressure MPa	Air consumption L/min	Paint flow rate mL/min	Pattern width mm	Air cap model	Mass g
Automatic	ZP2-A20	Pressure	2.0	0.34	500	380	380	ZP2-R1Z	450
	ZP2-A25		2.5		500	760	390	ZP2-R1Z	
Hand	ZP2-H20	Pressure	2.0	0.34	500	670	350	ZP2-R1Z	385
	ZP2-H25		2.5		500	760	370	ZP2-R1Z	

- The spray distance is 250 mm for all models.
- Paint viscosity for the ZP2: 20 sec / NK-2
- Nipple size for all models: Fluid nipple G3/8 (male), air nipple G1/4 (male)
- Refer to the details on related equipment on p. 4 when selecting the required compressor.
- * Manufactured to order

● Applications

Ideal for spraying enamel glaze, ceramic glaze, abrasives, and other highly abrasive materials

Ultra compact sized spray guns for use with mold release agents

TOF-50

These spray guns are designed specifically for use with a mold release agent in the manufacture of rubber moldings, resin moldings, die castings, and cast products. Using a dedicated spray gun for mold release agents ensures appropriate atomization and makes it easier to remove molded products from the mold, minimizing damage to both. The air and liquid connectors are configured at the bottom of the grip to ensure compact dimensions, light weight, and easy handling, making them ideal for applications in confined locations or at close range.

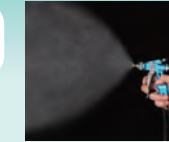

TOF-50
Ultra compact
sized manual
spray gun



Example showing special nozzle attached

Model	Type of feed	Nozzle orifice φmm	Atomizing air pressure MPa	Air consumption L/min	Liquid flow rate mL/min	Air cap model	Pattern width mm	Mass g
TOF-50-032P	Pressure (gravity/suction possible)	0.3	1.5	50	60	E2 (LPH-50)	90	260
TOF-50-042P		0.4			100		110	
TOF-50-062P		0.6			180		170	
TOF-50-082P		0.8			250		230	
TOF-50-102P		1.0			320		270	

- The spray distance for all models is 150 mm (spraying with water).
- Nipple size for all models: Fluid nipple φ6 x 4 mm (for tubes), air nipple φ6 x 4 mm (for tubes)
- Refer to the details on related equipment on p. 4 when selecting the required compressor.

COG

Cold Glue Gun

Spray guns for use with adhesives

COG

Spray guns suited to spraying adhesive (with viscosity up to around 3,000 MPa-s) for automotive interiors, wood, and insulation installation.



COG1-H08
Compact sized
manual spray gun

COG2-H18
Large sized
manual spray gun

COG2-A12
Automatic spray gun

* Photo depicts previous model.

	Model	Type of feed	Nozzle orifice φmm	Atomizing air pressure MPa	Air consumption L/min	Liquid flow rate mL/min	Pattern width mm	Air cap model	Mass g	
Hand	COG1-H08	Pressure	0.8	0.29	380	70	150	COG1	310	
	COG1-H12		1.2			90	170	COG1		
	COG1-H18		1.8			110	190	COG1		
	Automatic	COG2-H12	Pressure	1.2	0.29	440	150	265	COG2	375
		COG2-H18		1.8			250	290	COG2	
		COG2-H18S		Suction			1.8	410	110	
Automatic	COG2-A12	Pressure	1.2	0.29	440	150	265	COG2	420	
	COG2-A18		1.8			440	250	290		COG2

- The spray distance is 200 mm for all models.
- Nipple size for all models: Fluid nipple G3/8 (male), air nipple G1/4 (male)
- Refer to the details on related equipment on p. 4 when selecting the required compressor.
- Paint viscosity: 20 sec / NK-2

POG

Photocatalyst Gun

Spray guns for use with photocatalysts

LPH-50-S9/POG

The LPH Series offers further improvements in atomization and functionality.

- Applications**
Spraying photocatalyst liquids (The photocatalyst super-hydrophilic film may confer antifogging, antifouling, antibacterial, water purification, and gas decomposition characteristics.)
- Features**
 - Produces a flat spraying pattern with uniform particle size.
 - Maintains a large pattern width, even for low flow rate spraying.
 - Transfer efficiency can be increased by manually reducing the spray gun pressure.
 - Offers enhanced transfer efficiency when spraying at close range (approximately 150 mm).



Uses a quick fluid adjustment mechanism for fine adjustment of paint flow.

POG1L-H05-S23
Compact sized
manual spray gun

LPH-50-S9
Ultra compact sized
manual spray gun

Model	Type of feed	Nozzle orifice φmm	Atomization	Features	Applications
LPH-50-S9-04	Gravity	0.4	High atomization	Quick fluid adjustment mechanism	For interior painting
LPH-50-S9-10		1.0	High atomization		
POG1L-H05-S23		0.5	Ultra-high atomization		

- Liquid containers are sold separately.
- We recommend using stainless steel liquid containers/cups.

WIDER1A WIDER2A

General purpose automatic spray guns for use with paint

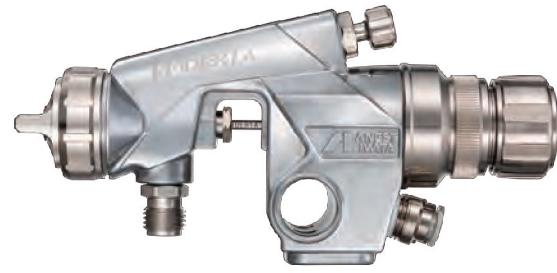

WIDER 1A
Compact sized

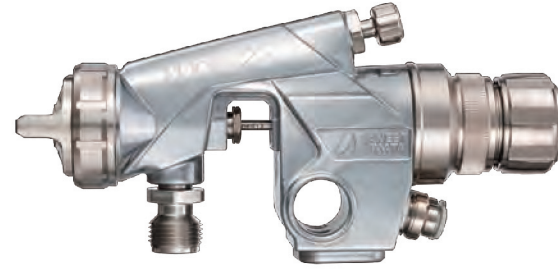

WIDER 2A
Large sized

Reliable quality and consistency A new model goes from "W" to "WIDER"

The key considerations for industrial painting products are quality and consistency. ANEST IWATA has developed a range of spray guns optimized to support ever diversifying applications and constantly evolving paints. The new WIDER models were developed based on the combined experience and expertise accumulated to date since the previous models, WA-101 and WA-200. The previously rugged styling has evolved into a more sophisticated design; the models feature improved ease of maintenance.

FEATURE 01 MAINTENANCE

New model offering easier maintenance

The various knobs are tapered with deep grooves to make fine adjustments even easier. Each nipple features a guide at the inlet to facilitate hose connections.

Air cap set

- The thread pitch was changed from 1 mm to 1.5 mm for easier attachment and detachment.
- The new design virtually eliminates air leaks from the air cap cover. Upgraded materials provide greater solvent resistance.



Air valve seat set

Previous models required a specialist tool to remove the valve seat; now this can be removed using a 14 mm box wrench.

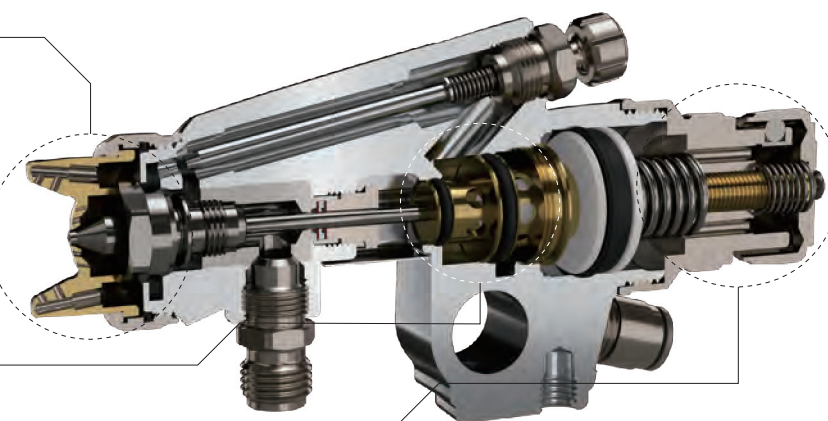
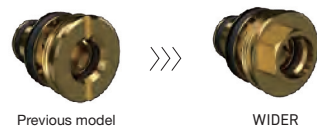

Fluid adjustment

Previous models required a 32 mm box wrench to remove the adjusters; now this can be removed without the use of tools.

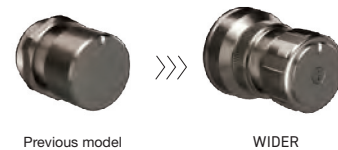

FEATURE 02 FEEL

Pattern adjuster with linear response

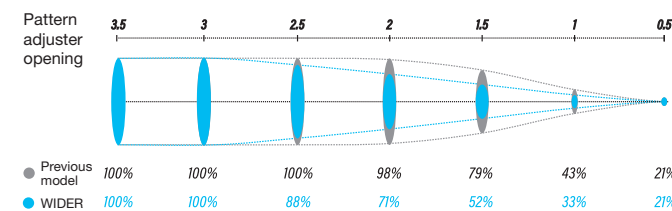

With the previous pattern adjuster, turning one revolution gave a pattern width of approximately 45 %; a 1.5-revolution turn gave a pattern width of approximately 80 %; and two revolutions resulted in a fully opened state with a pattern width of approximately 100 %. The newly developed pattern adjuster provides more intuitive linear response adjustments, with one revolution resulting in a pattern width of approximately 35 %; 1.5 revolutions resulting in a pattern width of approximately 50 %; and two revolutions resulting in a pattern width of approximately 70 %.

Component interchangeability

The figure to the right indicates components that are not interchangeable between the earlier WA-101 and the current WIDER1A and the earlier WA-200 and the current WIDER2A.

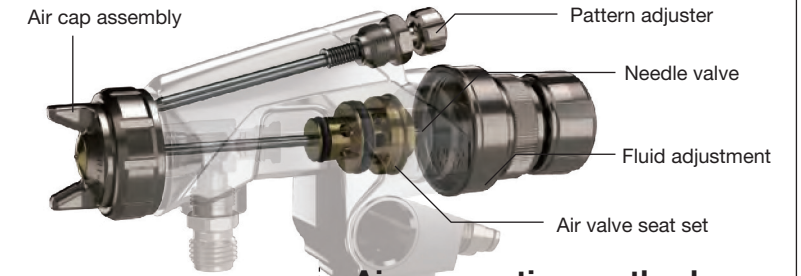

Needle packing set

Backed by a track record of more than 20 years, most of ANEST IWATA's manual spray guns and automatic spray guns employ needle packing of the same construction and materials. The packing for stopping the paint is made of a special composite material combining fluoro-resin (red) and rubber (black). The fluoro-resin blocks the paint, while the rubber ensures durability. The set of packing arranged in two rows so that even if the first seal starts to leak, the second seal will stop the paint. Ongoing minor improvements of materials have continually improved the already remarkable durability.

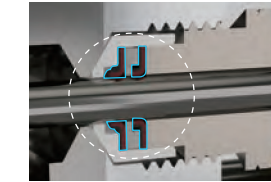

Air connection method

The WIDER models feature quick connect tube joints (atomization air: $\phi 8$ mm, operation air: $\phi 6$ mm) as standard. The air nipples provided with the products must be fitted for those using existing ANEST IWATA joints.



System diagram

Products in this series feature internal air valves to allow spraying with a single three-way solenoid valve. Atomization air can be left on to allow spraying without the need to set up a complex system. Note that remote control is not possible with these products; patterns must be manually adjusted by turning the pattern adjuster.

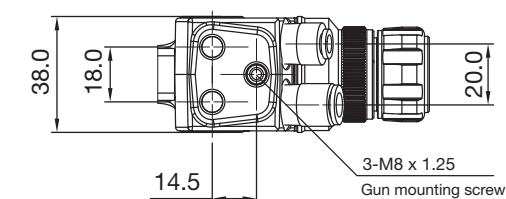
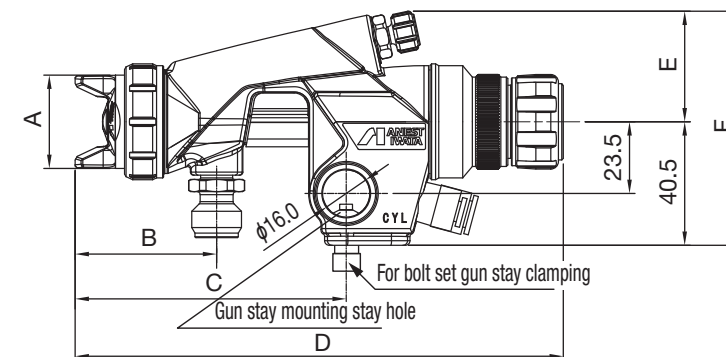
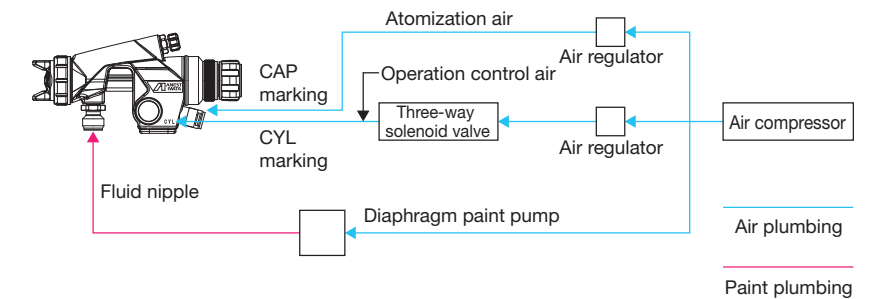

Mounting dimensions (mm)

Model	A	B	C	D	E	F
WIDER1A	27.0	43.5	85.5	158.5	162.5	36.0
WIDER1A(V)	27.0	43.5	85.5	158.0	162.5	36.0
WIDER1A-R	27.0	36.5	79.0	151.5	156.0	35.0
WIDER1A-R(V)	27.0	36.5	79.0	151.5	156.0	35.0
WIDER2A	30.5	46.5	89.0	160.0	165.5	36.0
WIDER2A(V)	30.6	46.5	89.0	160.0	165.5	36.0

* Dimension C is the same as for the previous models WA-101 and WA-200 and can be used without modifications.

	Previous model	Model	Type of feed	Nozzle orifice ϕ mm	Recommended conditions		Air consumption L/min	Pattern width mm	Air cap model	Spray pattern	Mass g
					Atomizing air pressure* MPa	Paint flow rate mL/min					
Compact sized	WA-101-082P (V)	WIDER1A-08E2P (V)	Pressure	0.8	150	270	190	WIDER1-E2P			
	WA-101-102P (V)	WIDER1A-10E2P (V)		1.0							
	WA-101-101P (V)	WIDER1A-10E1 (V)	Pressure (gravity/suction possible)	1.0	100	90	140	WIDER1-E1	Round/flat	425	
	WA-101-132P (V)	WIDER1A-13H2 (V)		1.3							
Large sized	WA-101R-05P (V)	WIDER1A-05R (V)	Pressure	0.5	20	40	35	WIDER1-05R	Round		
	WA-200-122P (V)	WIDER2A-12G2P (V)	Pressure (gravity/suction possible)	1.2	500	530	400	WIDER2-G2P			
	WA-200-152P (V)	WIDER2A-15K2 (V)		1.5							
	WA-200-202P (V)	WIDER2A-20R2 (V)	2.0	400	360	320	WIDER2-R2	Round/flat	445		
	WA-200-251P (V)	WIDER2A-25W1 (V)	2.5								

- The spray distance is 200 mm for WIDER1A and 250 mm for WIDER2A.
- WIDER1A: Fluid nipple G1/4 (male), air nipple: atomization air (CAP) $\phi 8$ mm, operation air (CYL) $\phi 6$ mm
- Refer to the details on related equipment on p. 4 when selecting the required compressor. ● Paint viscosity: 20 sec / NK-2
- * Models with the suffix "V" offer infinitely variable paint adjustment.

Automatic spray guns

Spray guns for use mounted on automated painting machines, reciprocators, or painting robots.

General purpose automatic spray guns

LPA-101
Compact sized,
HVLP



LPA-200
Large sized,
HVLP

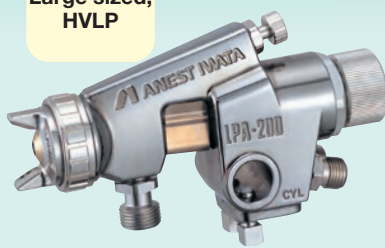

RK1-A05-0609
Single-side
angle

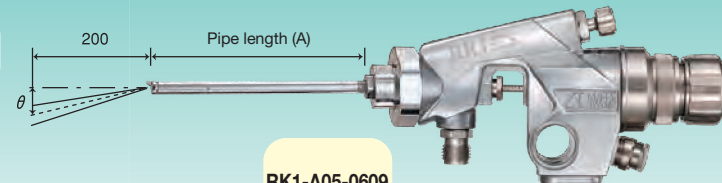

Model	Pipe length (A)	Pipe diameter	Pattern deflection angle (θ)
RK1-A05-0690	90 mm	6 mm	Approx. 4°
RK1-A05-09150	150 mm	9 mm	Approx. 14°
RK1-A06-12180	180 mm	12 mm	Approx. 19°

System diagram

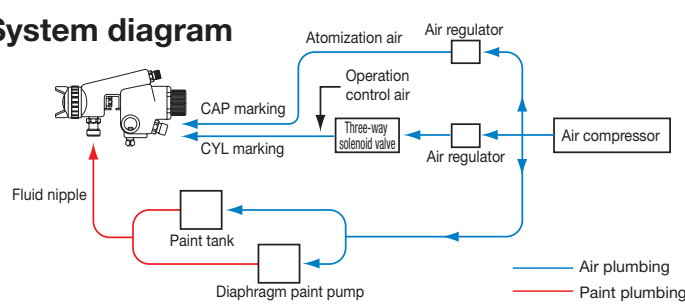

Products in this series feature internal air valves **to allow spraying with a single three-way solenoid valve.** (See the diagram to the left.) **Atomization air can be left on** to allow spraying without the need to set up a complex system. Note that remote control is not possible with these products; patterns must be manually adjusted by turning the pattern adjuster.

* For more information of the WIDER1A/2A Series normal pressure compact/large sized conventional automatic spray guns, refer to pp. 17-18.

High performance automatic spray guns

WRA-101
Compact sized



WRA-200
Large sized



LRA-200
Large sized,
HVLP



System diagram

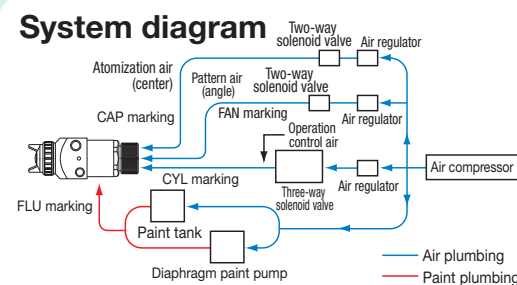

Compact type high performance automatic spray guns

- Independent control of the center air and angle air allows pattern widths to be adjusted remotely while painting, reducing overspray.
- Paint can be recirculated, which is convenient for paints such as metallic paint that easily precipitates.
- The compact body allows installation in confined spaces for use with automatic painting machines and painting robots.

Note ① These automatic spray guns do not include air valves. Refer to the system diagram to the left.
② The example shows mounting using commercial connectors.

Standard automatic spray gun

SGA-3
Standard



System diagram

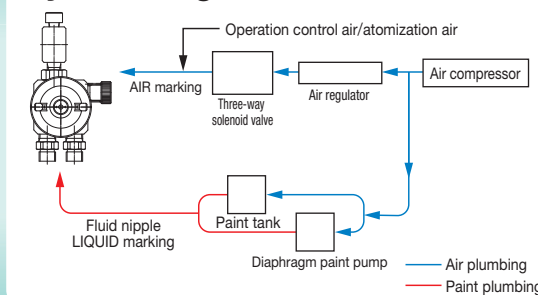

This simple automatic spray gun combines atomizing air and piston actuation air **to allow spraying with a single three-way solenoid valve (in practice, use with a two-way solenoid valve is also possible).** Note that **the atomizing air pressure must be at least 0.35 MPa** due to the need to operate the piston. This means this spray gun is **not suitable for subtle painting or low pressure spraying.** The pattern width is adjusted by turning the knob manually.

	Model	Type	Type of feed	Nozzle orifice	Spray gun inlet pressure	Air pressure inside air cap	Air consumption	Paint flow rate	Pattern width	Air cap model	Compressor requirements	Mass	Applications
				φmm	MPa	MPa	L/min	mL/min	mm	kW	g		
Conventional automatic spray guns	RK1-A05-0609	Single-side angle	Pressure (gravity)	0.5	0.29	—	35	4	32	—	0.4	455	For painting inside small cylindrical objects
	RK1-A05-09150			0.5			55	9	36		0.4	490	
	RK1-A06-12180			0.6			73	17	48		0.4	535	
High performance automatic spray guns	LPA-101-101P (V)	Compact sized	Pressure	1.0	0.26	0.07	410	150	200	E1	2.2 to 3.7	440	For painting small objects
	LPA-200-122P (V)	Large sized	Pressure	1.2	0.20		500	500	300	G2	2.2 to 3.7	470	For painting large objects
	WRA-101-082P (V)	Compact sized	Pressure	0.8	Atomization air 0.26, Pattern air 0.22		270	150	190	E2P	1.5	300	For painting small objects
High performance automatic spray guns	WRA-200-122P (V)	Large sized	Pressure	1.2	0.24, 0.26	0.07	530	500	400	G2P	2.2 to 3.7	325	For painting large objects
	LRA-200-122P (V)	HVLP	Pressure	1.2	0.14, 0.16		500	500	300	G2	2.2 to 3.7	325	For painting large objects
Standard automatic spray gun	SGA-3	Standard	Pressure (gravity)	1.0	0.24	—	80	—	—	E1	0.4 or greater	270	For spraying mold casting mold release agent and water-based solvents, etc.

- The spray distance is 200 mm for the RK (single-side angle)/LPA/WRA-101/LRA and 250 mm for the WRA-200.
- Paint viscosity: all models: 20 sec / NK-2
- The nipple size are as follows:
Fluid nipple G1/4 (male) for the RK (single-side angle)/LPA-101/SGA-3, G3/8 (male) for the LPA-200, Rc1/8 (female) for the WRA/LRA
Air nipple G1/4 (male) for the RK (single-side angle)/LPA-101/-200/SGA-3, Rc1/8 (female) for the WRA/LRA
- Refer to the details on related equipment on p. 4 when selecting the required compressor.

Automatic spray guns Mounting dimensions (mm)

Conventional automatic spray guns

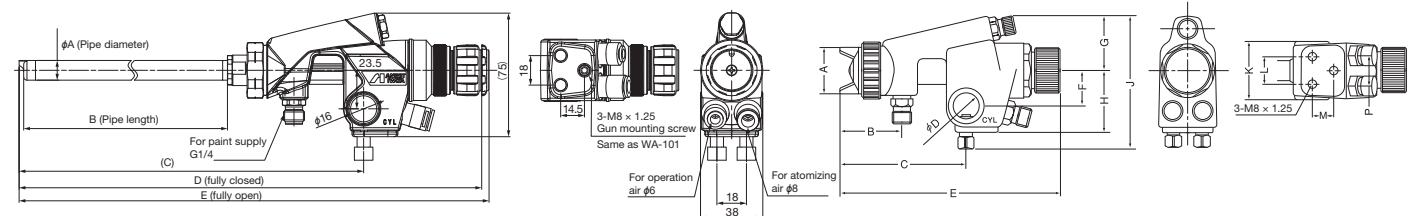

Model	A	B	C	D	E
RK1-A05-0690	6	90	175	247	252
RK1-A05-09150	9	150	236	308	312
RK1-A06-12180	12	180	266	338	343

Model	A	B	C	D (φ)	E	F	G	H	J	K	L	M	P
LPA-101	27	47	88.5	16	150	23.5	36	40.5	86	38	18	14.5	20
LPA-200	30.5	47.5	89	16	148.5	23.5	36	40.5	86	38	18	14.5	20

High performance automatic spray guns

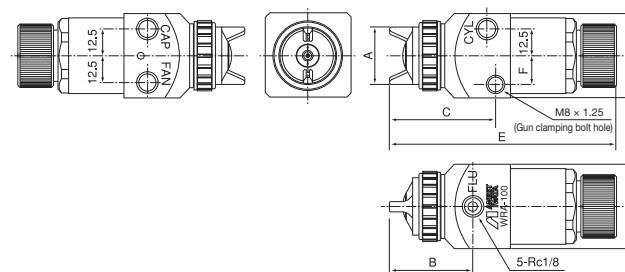

Model	A	B	C	D (φ)	E	F	G	H	J	K
WRA-101	27	40	51	—	109	14.5	—	—	40	40
WRA-200	30.5	48	56	—	111	14.5	—	—	40	40
LRA-200	30.5	48	56	—	111	14.5	—	—	40	40

Standard automatic spray gun (SGA-3)

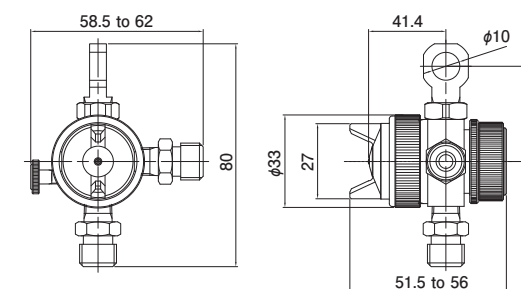

Diaphragm paint pump with raising/lowering stand

- This stand type device allows the pump to be moved up and down to facilitate paint replenishment.
- Ideal for use when multiple units are lined up to supply paint for multiple color painting lines.

DPS-90LE

The paint can is not included. The agitator is optional.



High performance manifold automatic spray gun

WRA-M200

Manifold

A manifold refers to a spray gun in which the main automatic spray gun unit is separate from the stay attachment (manifold).

- The automatic spray gun body allows maintenance without removing air or paint tubes.
- The automatic spray gun body can be quickly replaced as a unit if problems arise with the cap nozzle during painting.
- With spindle painting, the spray gun can be easily returned to the origin position without changing the fixed stay setting.



WRA-M200

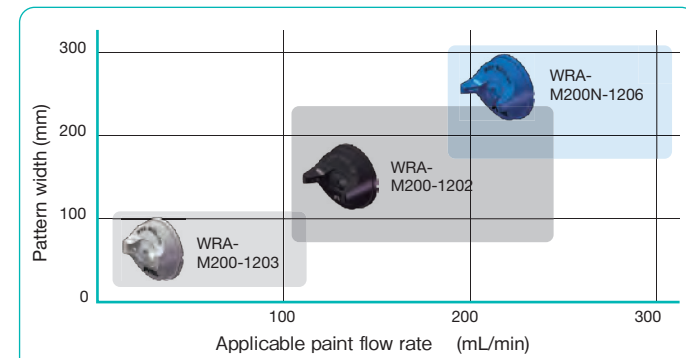

Cap/nozzle/body variations

Various different air caps and nozzle orifice diameters can be combined to allow use across a wide range of commercial applications. The body and manifold are available in a choice of aluminum + alumite or stainless steel specifications to allow use even with water-based paints.

High work efficiency

The included spring plunger allows easy alignment of the air cap. As it can be rotated in only one direction, it can be adjusted to the 0 or 90 degree position without the need for visual confirmation. Intermediate adjustments are also possible.



Ease of maintenance

The fluid adjustment can be removed without tools.



The design separates the paint path and the piston chamber to make it easy to check the degree of wear of sliding parts such as the needle and needle packing. The cover on the needle packing also functions as a tool for retightening the needle packing. In addition to allowing early detection of paint leaks, this allows the needle packing to be retightened without disassembly.



System diagram

- Independent control of the center air and angle air allows pattern widths to be adjusted remotely while painting, reducing overspray. Models in this series do not include an air valve.
- Paint can be recirculated, which is convenient for paints such as metallic paint that easily precipitates.
- The compact body allows installation in confined spaces for use with automatic painting machines and painting robots.

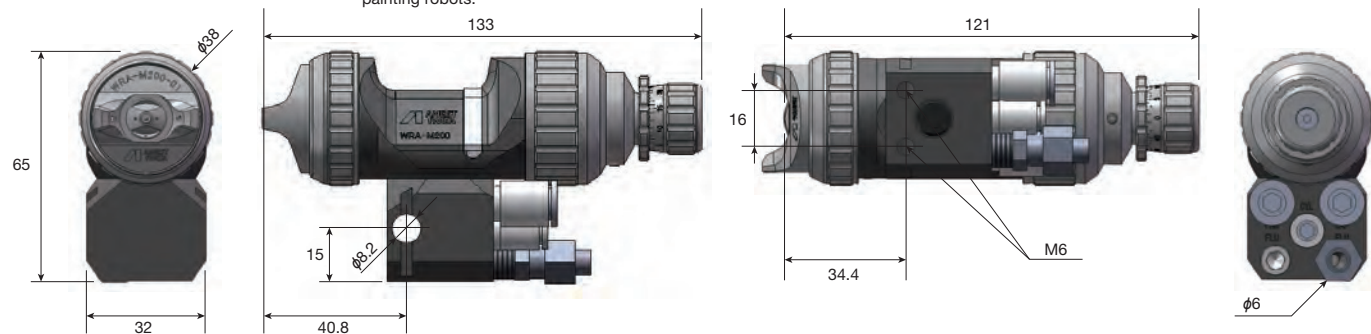
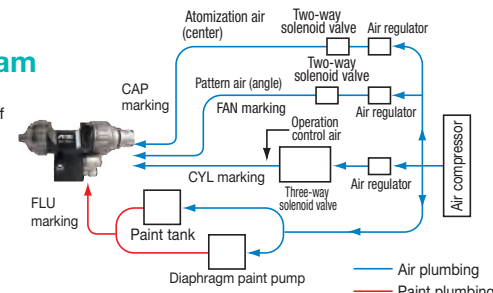

Model	Type of feed	Nozzle		Air cap model	Recommended conditions			Atomization air mL/min	Pattern width mm	Body/manifold material	Mass g
		Orifice φmm	Shape		Spray gun inlet pressure MPa		Paint flow rate mL/min				
					Atomization air	Pattern air					
WRA-M200-1202	Pressure	1.2	Straight	02	0.23	0.22	200	360	180	Aluminum + alumite	350
WRA-M200-1203		1.2		03	0.11	0.12	80	200	100		
WRA-M200N-1206		1.2		06	0.16	0.16	200	430	300		

● The spray distance is 200 mm for the WRA-M200-1202, 150 mm for the -1203, and 300 mm for the N-1206. ● Paint viscosity: 12 sec / NK-2
● Refer to the details on related equipment on p. 4 when selecting the required compressor.

Air dusters/Blow guns

AG-6/AG-4/ADP

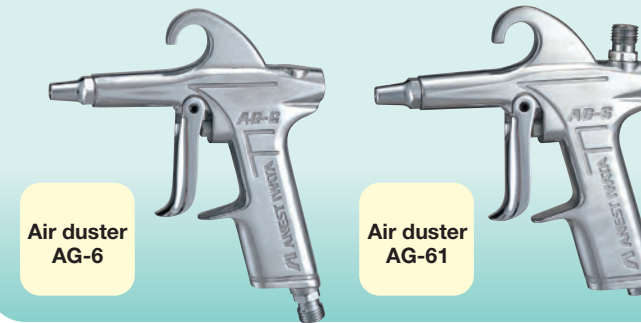

Air duster AG-6

Air duster AG-61

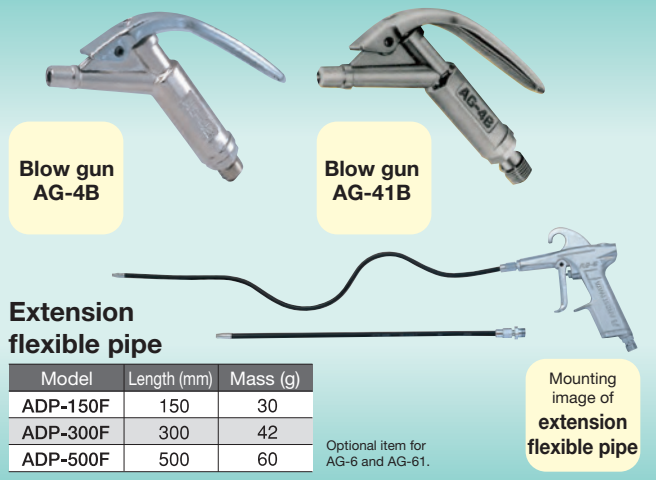

Blow gun AG-4B

Blow gun AG-41B

Extension flexible pipe

Model	Length (mm)	Mass (g)
ADP-150F	150	30
ADP-300F	300	42
ADP-500F	500	60

Optional item for AG-6 and AG-61.

Mounting image of extension flexible pipe

Model	Nozzle orifice φmm	Atomizing air pressure MPa	Air consumption L/min	Compressor requirements kW	Mass g	Connector screw thread diameter	Applications
AG-6	1.7	0.34	105	0.4	185	G1/4 (male)	Blowing away dust and chips from equipment
AG-61	1.7	0.34	105	0.4	185	G1/4 (male)	
AG-4B	4.5	0.59	970	1.5 to 5.5	218	G3/8 (male)	Blowing away dust and chips from equipment
AG-41B	4.5	0.59	970	1.5 to 5.5	212	G1/4 (male)	

Aqua dry gun (For water-based paints)

ADG-1BV

Amplifies the force of minute air volumes. Ideal for slow-drying water-based paints. Also suitable for use with drying solvent-based paints. Model: ADG-1BV Mass: 425 g Air nipple: G1/4 (male) Includes a handy valve near the grip for turning flow on and off.

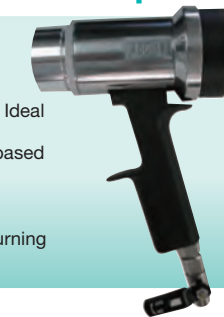

Spray gun cleaner UG-3000C

- Simply place spray guns and cups inside the cleaning chamber and depress the pedal to automatically clean paint passages and exterior surfaces.
- Cleaning thinner can be reused.
- Prevents scattering of mist and odors to enhance work environments.



Drive type	Compressed air
Pump type	Air driven diaphragm pump
Timer type	Clockwork mechanical timer (cleaning time set to 47 seconds)
Supply air pressure	0.49 to 0.59 MPa
Air consumption	50 to 150 L/min (for 0.49 MPa supply air pressure)
Flow rate	Approx. 12 to 15 L/min (for 0.49 MPa supply air pressure)
Cleaning fluid	Cleaning thinner
Air connector	Rc1/4 (female)
Operation	Pedal-operated
Compatible cans	18 L rectangular can, 20 L pail
Cleaning chamber material	Stainless steel
Dimensions	Overall length 345 mm × overall width 440 mm × overall height 990 mm
Mass	22 kg
Ambient temperature range	5 to 45 °C (no freezing)

Handy air pressure gauge AJR-02S-VG

Allows operators to check the spray gun inlet pressure. The compact, lightweight, easy-to-use, straight screw type allows fine adjustments, and does not interfere with the handling of the spray gun when mounted. Model: AJR-02S-VG Mass: 120 g Adjustment method: Screw type Air nipple: G1/4 (male)



HOLDERS

Compatible spray guns: W-300/LPH-300/WIDER4/WIDER4L

Spray gun holder (For center cup spray guns) GH-WH-02

The included pedestal allows installation anywhere. The spray gun can be mounted to a wall with the air hose attached. Model: GH-WH-02 Mass: 510 g

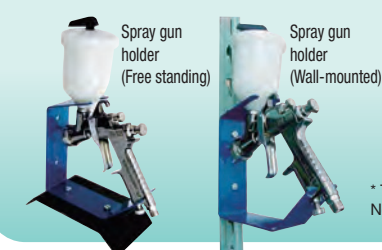

Magnetic spray gun holders (for center cup spray guns) and hose holder

These powerful magnets provide secure mounting of spray guns containing paint while allowing the stand to be easily moved. No drilling or screwing into the wall is required.

Model	Product	Remarks	Maximum load*
GHM-01	Magnetic single gun holder	Spray gun holder (one spray gun)	3 kg
GHM-03	Magnetic triple gun holder	Spray gun holder (three spray guns)	10 kg
GAHM-01	Gun adapter holder	Adapter for PPS cup	—
HHM-01	Magnetic hose holder	Air hose holder	20 kg

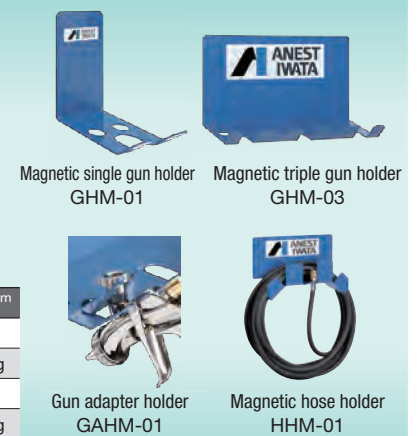

* The maximum load is based on ANEST IWATA measurements. Attach securely to a flat surface. Check the mounting before use. Note: Attach the GAHM-01 gun adapter holder to the gun holder when using a 3M™ PPS™ cup. It cannot be used on its own.

Airbrushes

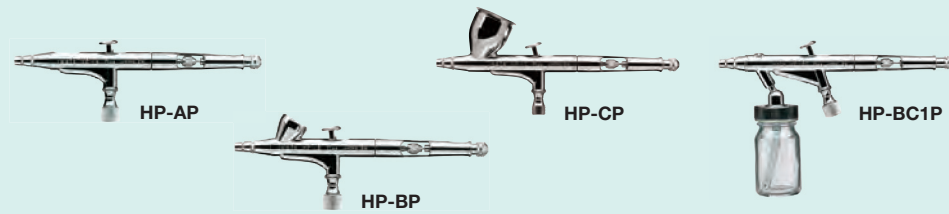

* Models other than those shown in this catalog are also available. Please refer to the general catalog for airbrushes for more information.

Series	Model	Type of feed	Nozzle orifice φmm	Capacity mL	Type of pattern	Standard spray pressure MPa	Operating method	Remarks
Custom Micron	CM-B2	Gravity	0.18	1.5	Round		Double-action	—
	CM-C2	Gravity	0.23	7.0	Round	0.10 to 0.20	Double-action	—
	CM-CP2	Gravity	0.23	7.0	Round		Double-action	With air adjuster knob
Hi-Line	HP-CH	Gravity	0.3	7.0	Round	0.10 to 0.29	Double-action	—
	HP-TH	Gravity	0.5	15	Round/flat	0.10 to 0.15	Trigger action	With center cup (HPA-CB1)
HP plus	HP-AP	Gravity	0.2	0.4	Round		Double-action	—
	HP-BP	Gravity	0.2	1.5	Round	0.10 to 0.29	Double-action	—
	HP-CP	Gravity	0.3	7.0	Round		Double-action	—
	HP-BC1P	Suction	0.3	20	Round		Double-action	With glass bottle
	HP-BS	Gravity	0.3	1.5	Round		Double-action	—
Eclipse	HP-BCS	Suction	0.5	60	Round	0.10 to 0.29	Double-action	With bottle cup
	HP-G3	Gravity	0.3	130	Round/flat		Trigger action	Gun type model With center cup (HPA-GC1)
	HP-G5	Gravity	0.5	220	Round/flat	0.10 to 0.15	Trigger action	Gun type model With center cup (HPA-GC2)
	HP-G6	Suction	0.6	84	Round/flat		Trigger action	Gun type model With two bottles (84 mL) (HPA-PBT84-G6) and adapter
Revolution	HP-CR	Gravity	0.5	7.0	Round		Double-action	—
	HP-TR1	Gravity	0.3	7.0	Round	0.10 to 0.29	Trigger action	With side cup
	HP-TR2	Gravity	0.5	15	Round		Trigger action	With side cup

● Air inlet: G1/8 (male), G1/4 (male) for gun type models.

Compressors



IS-925HT/875HT



IS-925/876



IS-976MB

Model	Rated power consumption W	Maximum operating pressure MPa	Air flow		Mass kg	External dimensions W x D x H mm	Noise level dB	Tank capacity L	Remarks
			At no load L/min	At 0.2 MPa L/min					
IS-875HT	150/200 (50/60Hz)	0.42	18	15	5.5	280 x 160 x 275	Max. 60	0.45	Includes filter regulator, hose, and airbrush holder.
IS-925HT	220/290 (50/60Hz)	0.42	36	23	7.1	280 x 160 x 330	Max. 60	0.48	
IS-876	91 (50/60Hz)	0.34	10.5	5	5.45	257 x 241 x 140	Max. 55	—	Includes built-in filter regulator, hose, and airbrush holder.
IS-925	125 (50/60Hz)	0.42	22.6	6.7	7.9	310 x 156 x 260	Max. 55	—	
IS-976MB	115/145 (50/60Hz)	0.40	22.6	12	12	360 x 200 x 640	Max. 55	2.5	Includes filter regulator, hose, and airbrush holder.

Airbrush kits



HP-S51-K



HP-ST800-PK



HP-ST850-TR1

* Models other than those shown in this catalog are also available. Please refer to the general catalog for airbrushes for more information.

Model/Kit name	HP-S51-K Starter kit	HP-ST800-PK Standard kit	HP-ST850-TR1 Standard kit (trigger)
Kit contents	Airbrush (HP-CR) Compressor (IS-51)	Airbrush (HP-CP) Compressor (IS800J)	Airbrush (HP-TR1) Compressor (IS-850)

Air hose connection

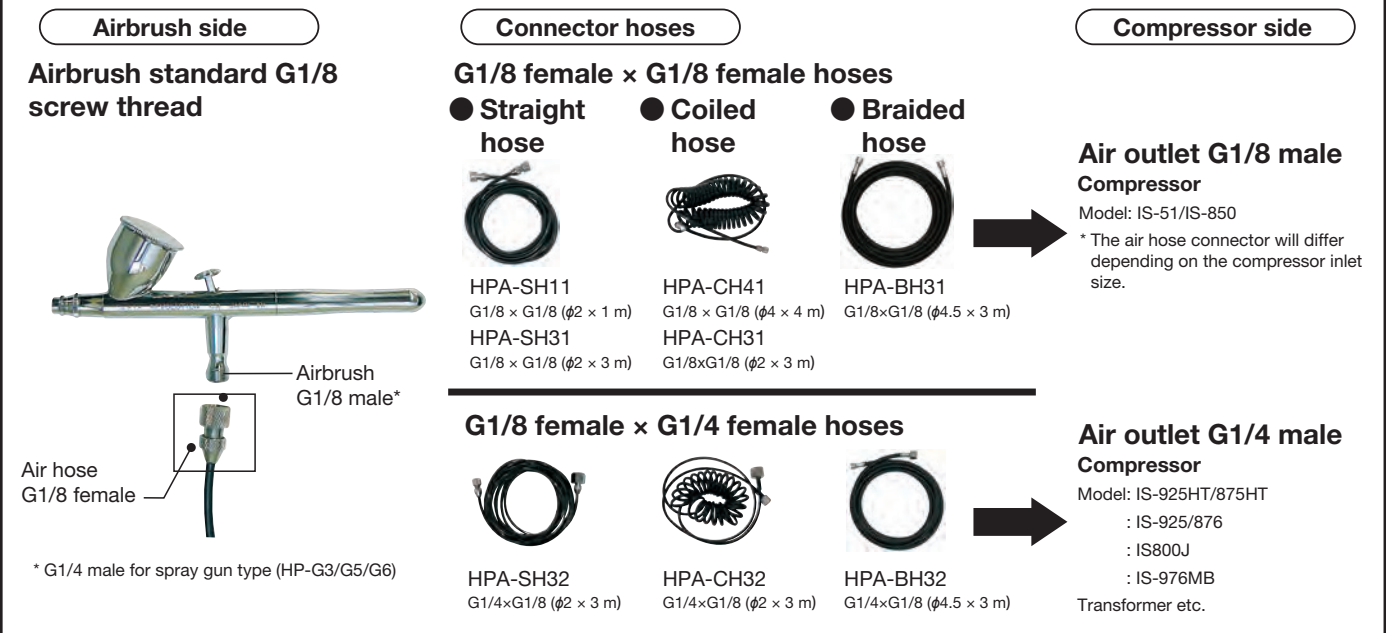

'kiwami

Designed 'kiwami as a standalone brand aiming for even greater heights

Inheriting the specifications of the WIDER1 following its new model change

ANEST IWATA believes the key requirement for automotive refinish spray guns is the ability to quickly adapt to evolving paints and maximize the performance of paints to achieve attractive paint finishes with ease. A spray gun must be the "ultimate tool" for our customers. It has been 14 years since the launch of the Bisho series of 2K paint spray guns, and 10 years since the launch of the Kiwami series of 1K high-solid paint spray guns. Now, products must meet demands for environmental friendliness, worker safety, simplified work procedures, and improved quality. ANEST IWATA aims to further raise the levels of excellence to provide the ultimate tool to our customers.



'kiwami Standard

This ultimate spray gun is optimally matched to the high-solid paints that currently comprise mainstream use. The 'kiwami combines a flat wide pattern suited to high-solid paint with optimal wet coat spray characteristics for further enhanced atomization performance.



KIWAMI-1-13B8
Base coat



KIWAMI-1-14B8
Clear coat

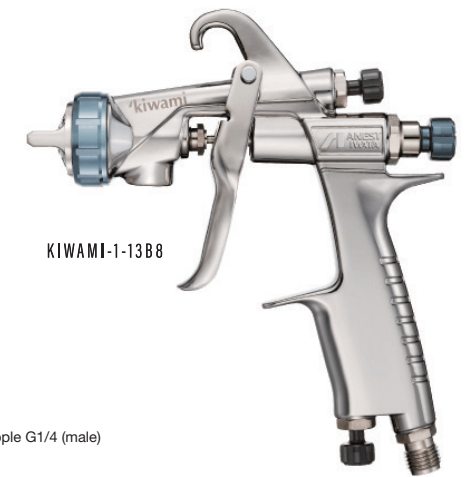

KIWAMI-1-13B8

Previous model	Model	Nozzle orifice φmm	Atomizing air pressure MPa	Air consumption L/min	Paint flow rate mL/min	Pattern width mm	Air cap model	Mass g
W-101-138BGC	KIWAMI-1-13B8	1.3	0.20	230	185	260	B8	290
W-101-148BGC	KIWAMI-1-14B8	1.4			200	275		

● The spray distance is 200 mm for all models. ● Paint viscosity: 12 sec / NK-2 ● Nipple size for all models: Fluid nipple G1/4 (male), air nipple G1/4 (male)
● Refer to the details on related equipment on p. 4 when selecting the required compressor. ● The paint cup is not included.

'kiwami RT Revolutionary Technology

These latest spray gun models are compatible with paints that are difficult to apply. They ensure uniform film thickness and particle size within the pattern and are compatible with various increasingly popular paint types, such as color clear, gun metallic, and pearl base, to achieve optimal wet paint films. The 'kiwami represents the painstaking pursuit of excellence from the customer's perspective, based on guidance from ANEST IWATA's technical painters.



KIWAMI-1-13B10
Base coat

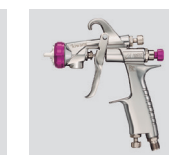

KIWAMI-1-16B12
High-solid clear



YouTube

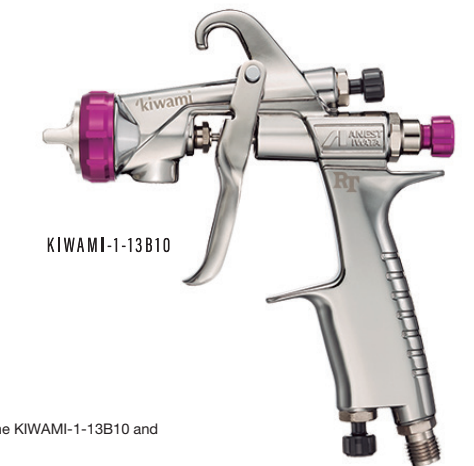

KIWAMI-1-13B10

Previous model	Model	Nozzle orifice φmm	Atomizing air pressure MPa	Air consumption L/min	Paint flow rate mL/min	Pattern width mm	Air cap model	Mass g
W-101-1310BG	KIWAMI-1-13B10	1.3	0.15	200	140	240	B10	290
W-101-1310BG	KIWAMI-1-16B12	1.6	0.18	220	155	275	B12	290

● The spray distance is 150 mm for the KIWAMI-1-13B10 and 200 mm for the KIWAMI-1-16B12. ● The paint viscosity is 12 sec / NK-2 for the KIWAMI-1-13B10 and 15 sec / NK-2 for the KIWAMI-1-16B12. ● Nipple size for all models: Fluid nipple G1/4 (male), air nipple G1/4 (male)
● Refer to the details on related equipment on p. 4 when selecting the required compressor. ● The paint cup is not included.

Recommended 'kiwami model for Kansai Paint

The optimal spray gun for paint. These spray guns are created in collaboration with a paint manufacturer. These 'kiwami models have been fine-tuned for use with the Retan PG Hybrid Eco HS system.



KIWAMI-1-13KP6
Base coat



KIWAMI-1-14KP6
Clear coat

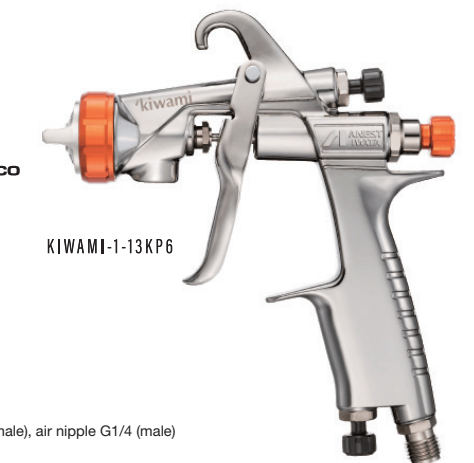

KIWAMI-1-13KP6

Previous model	Model	Nozzle orifice φmm	Atomizing air pressure MPa	Air consumption L/min	Paint flow rate mL/min	Pattern width mm	Air cap model	Mass g
W-101-136KPGC	KIWAMI-1-13KP6	1.3	200	0.20	165	240	KP6	290
W-101-146KPGC	KIWAMI-1-14KP6	1.4			170	245		

● The spray distance is 200 mm for all models. ● Paint viscosity: all models: 12 sec / NK-2 ● Nipple size for all models: Fluid nipple G1/4 (male), air nipple G1/4 (male)
● Refer to the details on related equipment on p. 4 when selecting the required compressor. ● The paint cup is not included.

'kiwami (Former Bisho Series)

These spray guns are optimally set up for 2K paints. The new 'kiwami Series lineup retains the performance of the former Bisho Series. The 'kiwami can be used with the same feel from undercoat to base and clear coats.



KIWAMI-1-13B4
Metallic/pearl



KIWAMI-1-14B2
Solid/clear



KIWAMI-1-16B2
Primer surfacer

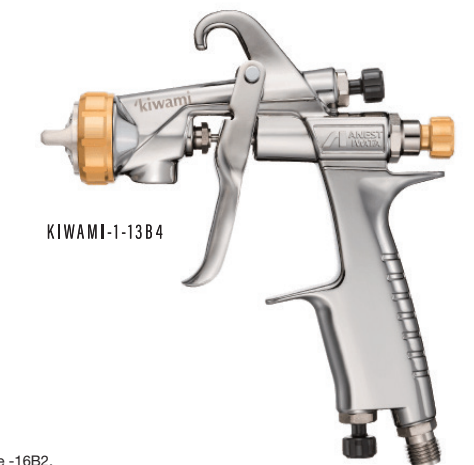

KIWAMI-1-13B4

Previous model	Model	Nozzle orifice φmm	Atomizing air pressure MPa	Air consumption L/min	Paint flow rate mL/min	Pattern width mm	Air cap model	Mass g
W-101-134BPG/C	KIWAMI-1-13B4	1.3	0.20	160	140	250	B4	290
W-101-142BPG/C	KIWAMI-1-14B2	1.4	0.24	230	200	270	B2	290
W-101-162BPG/C	KIWAMI-1-16B2	1.6	0.24*		195	200		

● The spray distance is 200 mm for all models. ● The paint viscosity is 12 sec / NK-2 for the KIWAMI-1-13B4/14B2 and 20 sec / NK-2 for the -16B2.
● Nipple size for all models: Fluid nipple G1/4 (male), air nipple G1/4 (male)
● Refer to the details on related equipment on p. 4 when selecting the required compressor. ● The paint cup is not included.

SELECTION CHART

Primer surfacer

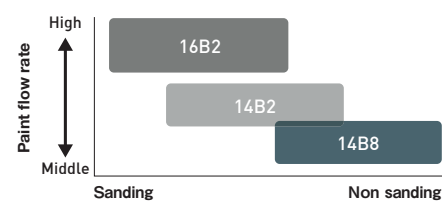

Base coat

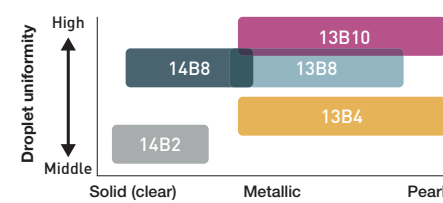

Clear coat

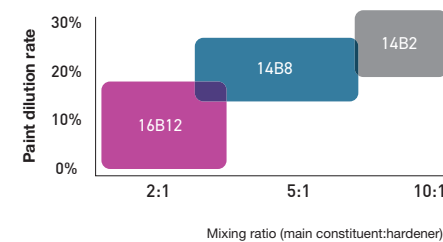

'kiwami RT aqua Revolutionary Technology

Designed specifically for water-based paints, the KIWAMI-1-18B14 RT aqua has been newly added to the KIWAMI-1 Series. While water-based paints previously presented problems with the KIWAMI-1 side cup model, the 1.8 mm large-diameter nozzle provides a 60 % greater paint flow rate (compared to the KIWAMI-1-14B8) while maintaining atomization using the dedicated B14 "aqua" cap designed specifically for use with water-based paints.

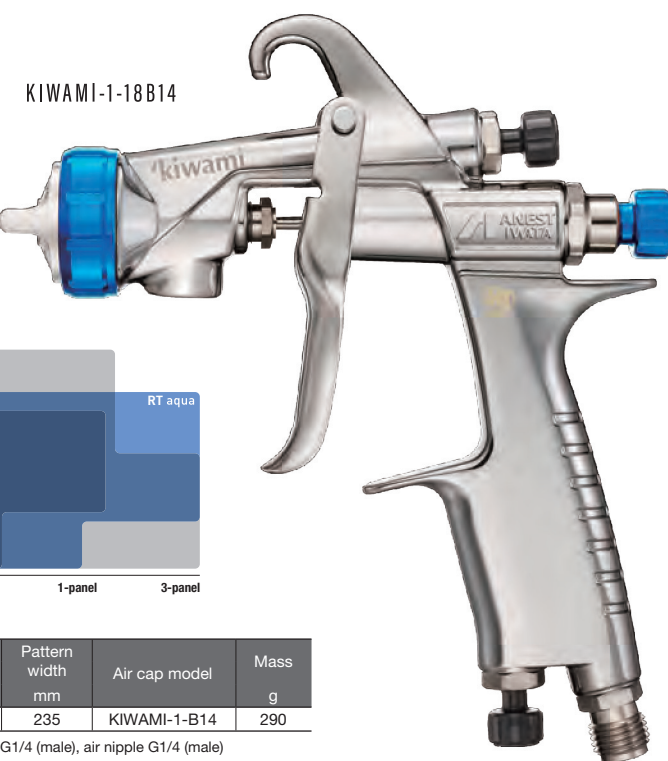

KIWAMI-1-18B14



KIWAMI-1-18B14
Base coat



YouTube

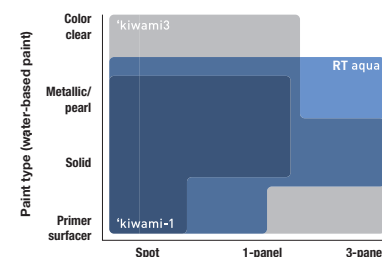

Model	Type of feed	Fluid nozzle		Atomizing air pressure MPa	Paint flow rate mL/min	Air consumption L/min	Pattern width mm	Air cap model	Mass g
		Orifice φmm	Shape						
KIWAMI-1-18B14	Gravity	1.8	Straight	0.15	175 (3 turns)	180	235	KIWAMI-1-B14	290

● The spray distance is 150 mm. ● Paint viscosity: 15 sec / NK-2 ● Nipple size for all models: Fluid nipple G1/4 (male), air nipple G1/4 (male)
● Refer to the details on related equipment on p. 4 when selecting the required compressor.

'kiwami 3

Compact sized spray gun

With the first full model change from the W-300 launched 20 years before, the 'kiwami3 model has just been added to the 'kiwami range of automotive refinish spray guns.

It inherits the features of the updated WIDER3 while offering completely new functions and design that make it even easier to use and give it a sophisticated new look.

■ Features

* In addition to improved work efficiency, now compatible with water-based primer surfacer

The W-300, the previous model, has been updated to improve performance with a pattern width of +15 mm and a paint flow rate of +5 mL/min.

* Improved handling performance

Incorporating an ergonomic design focused on functionality, the trigger is shaped to improve usability for low flow rate painting. The overall weight is 5 g lighter than the previous model, and the grip has been extended to move the center of gravity closer to the hand.

* Ease of maintenance

The cap screw thread pitch has been changed to allow removal in approximately half the time. A groove behind the needle valve allows easy attachment and detachment.

* Consistent painting with minimal individual variations

The air valve construction has been revised to increase and standardize the opening size to minimize pressure losses and reduce variations dependent on the screw position.

* Unchanged ease of cleaning and corrosion resistance

The body features twilight chrome plating.

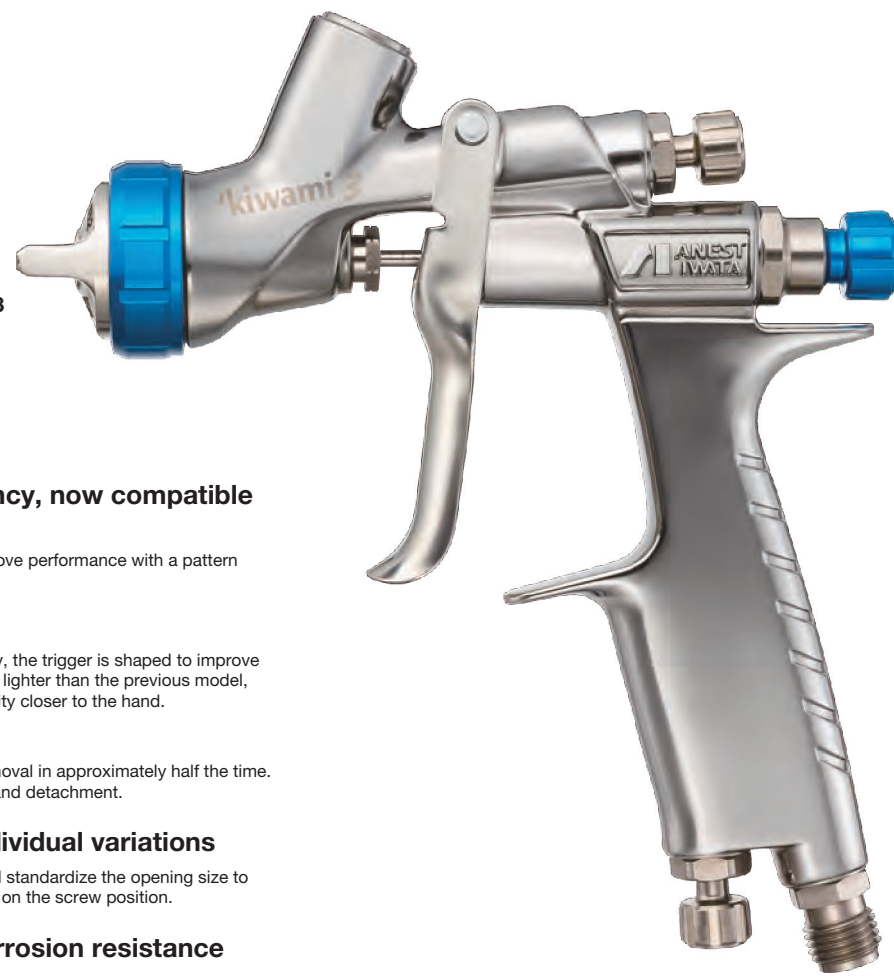

'kiwami 4

Large sized spray gun

With the first full model change from the W-400/LPH-400 launched 23 years before, the 'kiwami4 model has just been added to the 'kiwami range of automotive refinish spray guns.

It inherits the features of the updated WIDER4 while offering completely new functions and design that make it even easier to use and give it a sophisticated new look.

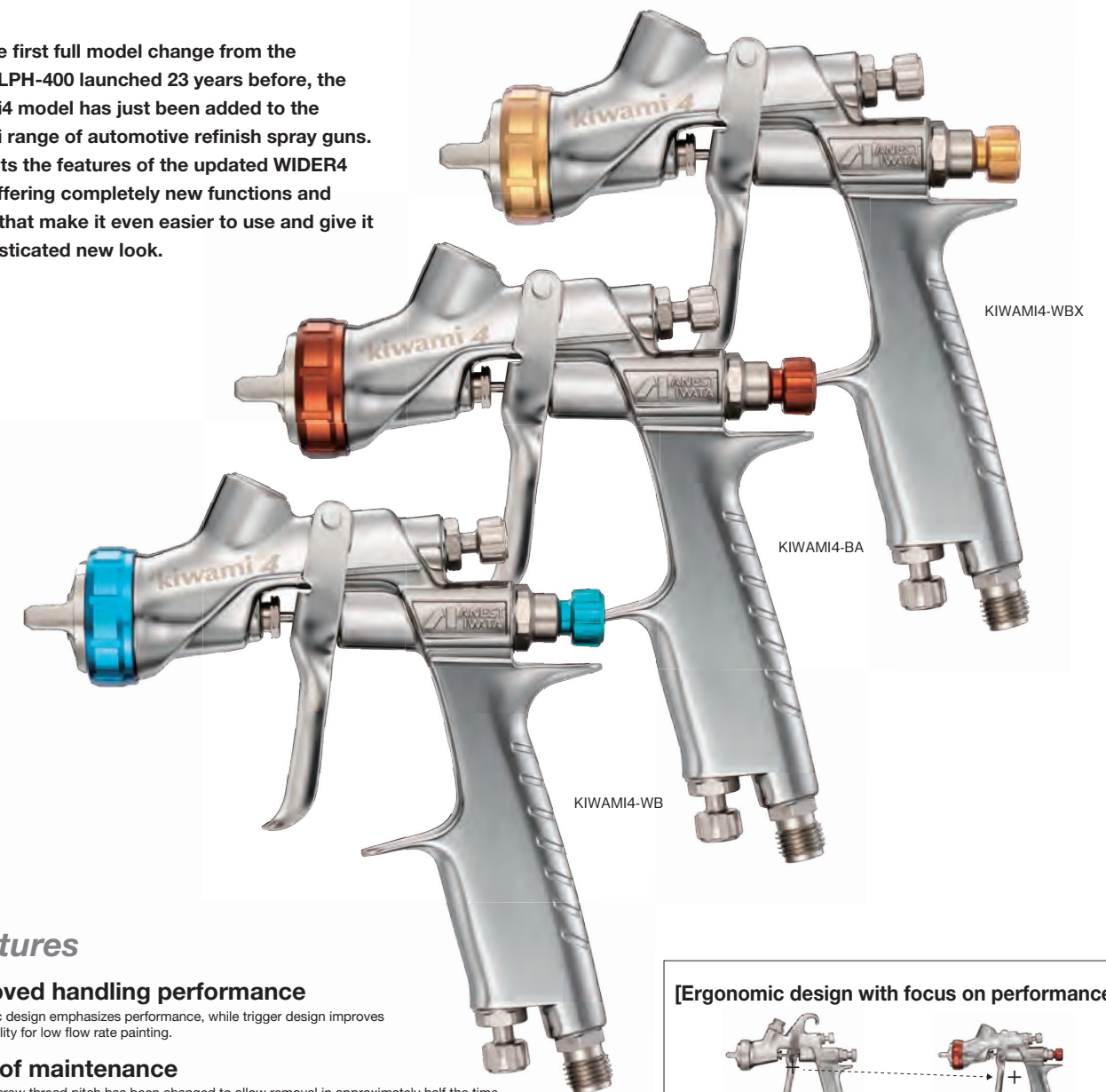

['kiwami 3 product placement]

■ Mapping including 'kiwami-1 and 'kiwami4

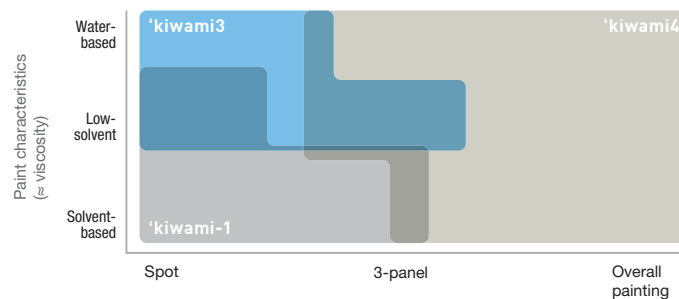

■ Differentiation from 'kiwami-1

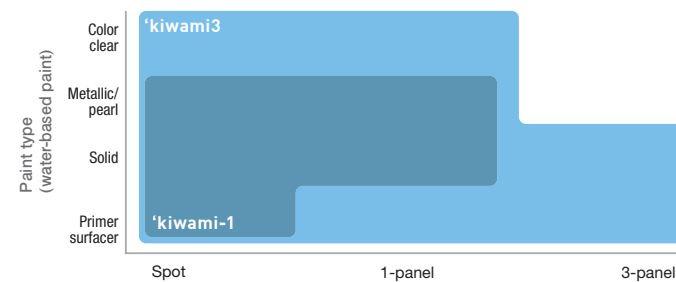

'kiwami-1 size compact center cup spray gun

Offers two major features compared to side cup types such as the 'kiwami-1.

1 Compatibility with high viscosity paint

The paint route from cup to nozzle is nearly straight. The paint route inside the center cup is large. This allows compatibility with high viscosity paints, even when using the same nozzle orifice diameter.

2 Excellent weight balance reduces fatigue

The cup is located over the spray gun's center of gravity so that the weight of the paint acts vertically on the operator's hand. This also makes it easier for left-handed operators to check painted surfaces while spraying.



■ Specifications

Previous model	Model	Type of feed	Fluid nozzle		Atomizing air pressure MPa	Paint flow rate mL/min	Pattern width mm	Air consumption L/min	Air cap model	Mass g
			Orifice φmm	Shape						
W-300WB-141G	KIWAMI3-V14WB2	Gravity	1.4	Split	0.15	130	265	230	KIWAMI3-WB	315
-	(Reference) W-300WB-141G	Gravity	1.4	Split	0.15	125	250	190	WB1	320

- The spray distance is 200 mm. ● Nipple size for all models: Fluid nipple G1/4 (female), air nipple G1/4 (male)
- Use the PC-G600P-2 (600 mL), PC-G400P-2 (400 mL), or PC-G2P-2 (200 mL) paint cups.
- Refer to the details on related equipment on p. 4 when selecting the required compressor. ● Paint viscosity: 20 sec / NK-2

■ Features

* Improved handling performance

Ergonomic design emphasizes performance, while trigger design improves controllability for low flow rate painting.

* Ease of maintenance

The cap screw thread pitch has been changed to allow removal in approximately half the time. A groove behind the needle valve allows easy attachment and detachment.

* Consistent painting with minimal individual differences and variations between lots

The air valve construction has been revised to increase and standardize the opening size to minimize pressure losses and reduce variations dependent on the screw position.

* The basic performance of the caps, nozzles, and needles remain unchanged.

■ Specifications

Previous model	Model	Type of feed	Fluid nozzle		Atomizing air pressure MPa	Air cap internal pressure MPa	Paint flow rate mL/min	Air consumption L/min	Pattern width mm	Air cap model	Mass g
			Orifice φmm	Shape							
W-400-134G	KIWAMI4-13BA4	Gravity	1.3	Straight	0.20	-	220	270	280	KIWAMI4-BA4J	355
W-400-144G	KIWAMI4-14BA4		1.4				250	270	300	KIWAMI4-BA4J	
W-400-164G	KIWAMI4-16BA4		1.6				285	270	330	KIWAMI4-BA4J	
W-400-184G	KIWAMI4-18BA4		1.8				360	270	375	KIWAMI4-BA4J	
W-400WB-122G	KIWAMI4-V12WB2		1.2				120	390	290	KIWAMI4-WB2J	
W-400WB-132G	KIWAMI4-V13WB2		1.3				160	390	300	KIWAMI4-WB2J	
W-400WB-142G	KIWAMI4-V14WB2		1.4	160	390	310	KIWAMI4-WB2J				
W-400WB-162G	KIWAMI4-V16WB2		1.6	250	390	340	KIWAMI4-WB2J				
W-400WBX-134G	KIWAMI4-V13WBX		1.3	195	370	390	KIWAMI4-WBXJ				
W-400WBX-144G	KIWAMI4-V14WBX		1.4	200	370	390	KIWAMI4-WBXJ				

- The spray distance is 200 mm for all models. ● Paint viscosity: 20 sec / NK-2 ● Nipple size for all models: Fluid nipple G1/4 (female), air nipple G1/4 (male)
- The PCG-6P-M paint cup for the previous model is not compatible. Use the PC-G600P-2 (600 mL) or PC-G400P-2 (400 mL) cups.
- Refer to the details on related equipment on p. 4 when selecting the required compressor.

[Ergonomic design with focus on performance]

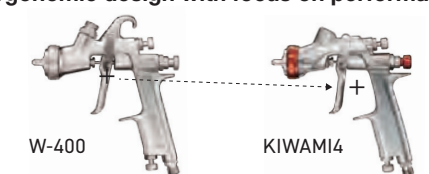

Overall weight has been reduced by 25 g compared to previous models. Overall length has been reduced and the grip has been lengthened to bring the center of gravity closer to the hand position. This greatly improves handling and reduces fatigue, which is expected to improve work efficiency.
* The center of gravity indicated in the photographs is for illustrative purposes.

kiwami^{mini} Ultra compact sized spray gun

W-50-136BGC

The W-50-136BGC with ultra compact body is a new addition to the 'kiwami series'. It inherits the flat wide pattern designed to maximize the characteristics of eco-friendly paints (e.g., 1K base coat paints). The essential aspects of ANEST IWATA's atomization technology have been combined and developed to achieve further excellence.



- Maintains large pattern width despite ultra compact dimensions.
- Spray mist atomization performance has been improved to achieve paint surface smoothness levels on par with the 'kiwami series'.
- The body uses the iconic "twilight chrome plating" of the ANEST IWATA 'kiwami series'. Its deep gloss creates a high quality feel.

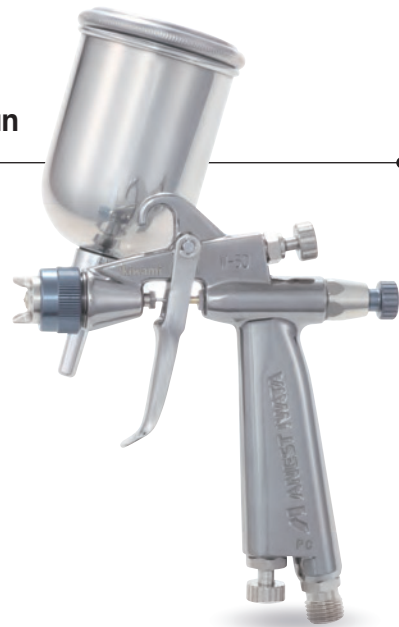

Spray patterns at the optimal pressure

	W-50-136BGC	KIWAMI-1-13B8
Gun pressure	0.15 MPa	0.2 MPa
Fluid adjustment opening	2.5 turns	2.5 turns
Spray distance	150 mm	200 mm
Air consumption rate	70 L/min	230 L/min
Paint flow rate	70 mL/min	145 mL/min
Pattern width	190 mm	240 mm

Achieves a flatter pattern than KIWAMI-1 when the flow rate is reduced by lowering the pressure to 0.1 MPa below the optimal pressure.

	W-50-136BGC	KIWAMI-1-13B8
Gun pressure	0.1 MPa	0.1 MPa
Fluid adjustment opening	2 turns	2 turns
Spray distance	100 mm	100 mm
Air consumption rate	55 L/min	150 L/min
Paint flow rate	40 mL/min	80 mL/min
Pattern width	120 mm	110 mm

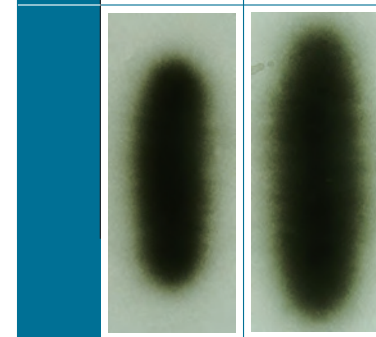

Operating ranges (illustrative)

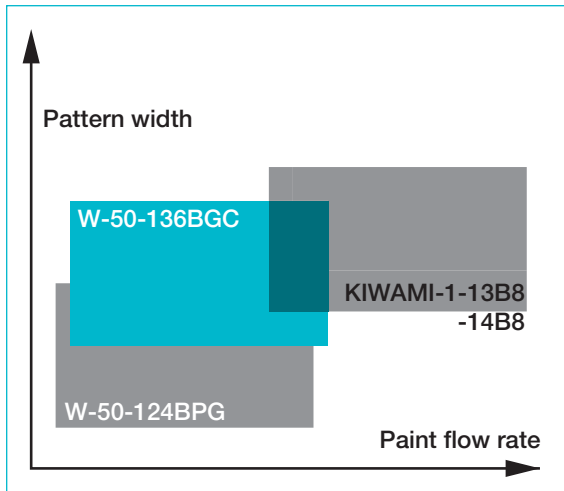

Specifications

Model	Type of feed	Nozzle orifice φmm	Atomizing air pressure MPa	Air consumption L/min	Paint flow rate mL/min	Pattern width mm	Air cap model	Compressor requirements kW	Mass g
W-50-136BGC	Gravity	1.3	0.15	70	85	190	W-50-B6	0.4	195

- The spray distance is 150 mm
- Nipple size: Fluid nipple G1/4 (male), air nipple G1/4 (male)
- Refer to the details on related equipment on p. 4 when selecting the required compressor.
- The PC-150SB-2LF cup is included (capacity: 130 mL, material: stainless steel, with variable angle arm)
- Paint viscosity: 12 sec / NK-2

This two-in-one model allows either suction feed or pressure feed to suit the working environment.

KIWAMI-1-14B8S

This is a 'kiwami series' spray gun suitable for use either as a suction feed or pressure feed device. It can be used with a large-capacity container cup for improved efficiency when spraying large areas. A paint hose from a supply pump can also be connected to use it as a pressure feed type, facilitating a wide range of painting jobs. The 1.4 mm nozzle orifice diameter is also compatible with a wide variety of paints.



Specifications

Model	Type of feed	Nozzle orifice φmm	Air cap model	Atomizing air pressure MPa	Air consumption L/min	Paint flow rate mL/min	Pattern width mm
KIWAMI-1-14B8S	Suction*1	1.4	B8	0.2	230	160	240
	Pressure*2	1.4	B8	0.2	230	180	250

- The spray distance is 200 mm for all models.
- *1: Paint viscosity 12 sec / NK-2 (automotive repair paint), *2: 20 sec / NK-2 (industrial paint)
- Nipple size for all models: Fluid nipple G1/4 (male), air nipple G1/4 (male)
- Refer to the details on related equipment on p. 4 when selecting the required compressor.
- Containers and cups are sold separately.

ANEST IWATA's supreme automotive refinish spray gun SUPER NOVA Series

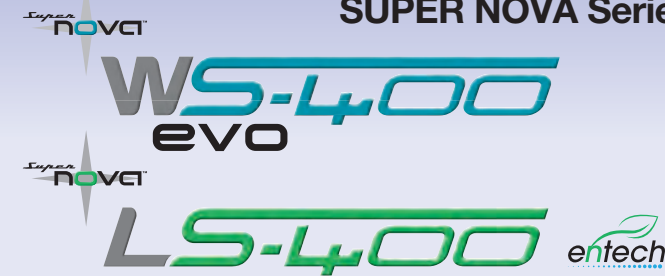

DESIGN

Designed by Pininfarina in Italy. Featuring styling that perfectly mates beauty with practicality.

PERFORMANCE

Designed specifically for water-based and high-solid clear paints. The LS-400, a low pressure version of the WS-400, offers larger droplet size than the WS-400 to reduce vaporization during painting. It is recommended especially for low humidity environments where a wet feel is required.

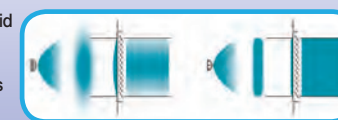

Specifications

Model	Nozzle orifice φmm	Atomizing air pressure MPa	Air consumption L/min	Paint flow rate mL/min	Pattern width mm	Pattern width mm	Pattern width mm	Air cap model	Mass g	Environment specifications
WS-400 EVO										
WS-400-1301B-S1	BASE 1.3			140						
WS-400-1301C-S1	CLEAR 1.3			170						Standard environment specifications
WS-400-1401B-S1	BASE 1.4			190	260	365				
WS-400-1401C-S1	CLEAR 1.4			220	265	365				
WS-400-1301BHS1	1.3 HD	0.2	370	220	265	365	Spray distance 200 mm	WS-400-01	695	
WS-400-1301CHS1	1.3 HD			240	270		Spray distance 300 mm		475	Dry environment specifications (high temperature/low humidity)
WS-400-1401BHS1	1.4 HD			260	275					
WS-400-1401CHS1	1.4 HD									
WS-400-1501BHS1*	1.5 HD									
WS-400-1501CHS1*	1.5 HD									
LS-400 ENTECH										
LS-400-1305-S1	ET 1.3			160	250	350				Standard environment specifications
LS-400-1405-S1	ET 1.4			170	260	360				
LS-400-1505-S1*	ET 1.5	0.18	400	180	265	365	Spray distance 200 mm	LS-400-05	695	
LS-400-ETS13-S1	ETS 1.3			160	235	310			400	Dry environment specifications (high temperature/low humidity) and long-distance spraying applications
LS-400-ETS14-S1	ETS 1.4		420	180	240	320			410	
LS-400-ETS15-S1	ETS 1.5			190	240	320			425	

- Nipple size for all models: Fluid nipple G1/4 (female), air nipple G1/4 (male)
- Paint viscosity: 20 sec / NK-2
- Refer to the details on related equipment on p. 4 when selecting the required compressor.
- With PC-G600P-2 paint cup (600 mL capacity), handy AJR-02S-VG pressure gauge, and dedicated wrench (provided in hard case)

Selection Guide

Body size	Type (Series name)	Large sized SUPER NOVA WS-400									
		-1301B-S1	-1401B-S1	-1301BH-S1	-1401BH-S1	-1501BH-S1	-1301C-S1	-1401C-S1	-1301CH-S1	-1401CH-S1	-1501CH-S1
Center cup	Recommended:	★	▶▶▶	◀◀◀	☆	▶▶▶	◀◀◀	★	▶▶▶	◀◀◀	▶▶▶
	Comments:	1K solvent-based Standard	Above 30 °C	Below 20 °C	Water-based Standard	Above 30 °C	Small area	Foreign clear Standard	Small area	Japanese clear Standard	Large area
	Booth interior temperature [°C]	Standard	Above 30 °C	Below 20 °C	Standard	Above 30 °C	Small area	Standard	Small area	Standard	Large area
	Booth interior humidity [%]	Standard	Above 30 °C	Below 20 °C	Standard	Above 30 °C	Small area	Standard	Small area	Standard	Large area
Primer surfacer	Sanding										
	Non sanding										
Base coat	Solvent (2K type)										
	Solvent (1K type)										
	Water-based										
Clear coat	Color clear										
	Standard										
High-solid	Standard										
	High-solid										

Temperature-humidity correlation for water-based base coat with WS-400/LS-400

Booth interior humidity [%]	Booth interior temperature [°C]			
	Above 40 °C	30 to 40 °C	20 to 30 °C	Below 20 °C
100 to 80%				
80 to 50%	1301BH	1301BH	1401B	1301B
50 to 40%	1401BH	1401BH	ETS13	ETS13
40 to 20%	1501BH	ETS14	ETS14	ETS14
20 to 0%	ETS15	ETS15	ETS15	ETS15

- Suffix "S1" is omitted from model codes.
- Reference values based on ANEST IWATA test data

Paint containers and paint supply units

Suction feed containers



Gravity feed cups



Cups with variable angle arm

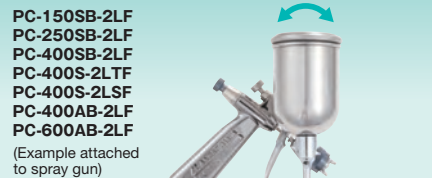

PC-150SB-2LF
PC-250SB-2LF
PC-400SB-2LF
PC-400S-2LTF
PC-400S-2LSF
PC-400AB-2LF
PC-600AB-2LF
(Example attached to spray gun)

Pressurized containers



Select the paint container to suit your particular paint volume and painting requirements.

① For touch-up and small-area painting: Gravity type side cup (130 to 600 mL)

② Medium-volume painting: Suction feed container (400 to 1,000 mL)

③ Medium-volume painting with pressure feed spray gun: Pressurized container (1,000 to 2,000 mL)

④ Factory line painting or continuous painting involving automated painting machines or robots: Pressurized paint tank (10 to 80 L) or diaphragm paint pumps are best suited.

Compatible spray gun * [Previous model]	Model	Capacity (mL)	Mass (g)	Body material	Remarks
Suction feed container * Model suffix "S" (Example: WIDER1-10E1S)					
WIDER1/1L [W-101/LPH-101]	PC-3	400	180	Aluminum	—
W-61/-71	PC-2	600	270	Aluminum	—
	PC-2-A	600	440	Aluminum	Cup with agitator
	PC-1S	1,000	330	Aluminum	—
	PCL-7B-2	700	370	Aluminum	Quick attachment type
	PCL-10B-2	1,000	410	Aluminum	With anti-spill feature
Mounting screw on spray gun: G1/4 (male)					
WIDER2 [W-200]	PC-1	1,000	335	Aluminum	—
W-77	PCL-7B-3	700	375	Aluminum	Quick attachment type
Mounting screw on spray gun: G3/8 (male)	PCL-10B-3	1,000	415	Aluminum	With anti-spill feature
Gravity feed cup (side cup) * Model suffix "G" (Example: WIDER1-10E1G)					
LPH-50	PC-61	130	110	Stainless steel	—
W-50	PC-51	220	126	Stainless steel	—
WIDER1/1L [W-101/LPH-101]	PC-5	250	135	Aluminum	—
KIWAMI-1	PC-4S	400	168	Aluminum	—
W-61/-71	PC-4S-A	430	430	Aluminum	Cup with agitator
RG-3L	PC-150SB-2LF	130	135	Stainless steel	—
	PC-250SB-2LF	220	160	Stainless steel	With arm, variable angle
	PC-400S-2LSF	400	220	Stainless steel	With arm, variable angle
	PC-400SB-2LF	400	210	Stainless steel	Seamless construction
	PC-400S-2LTF	400	210	Stainless steel + fluorine inner coating	—
	PC-400AB-2LF	400	125	Aluminum + alumite treatment	With arm, variable angle
	PC-600AB-2LF	600	155	Aluminum + alumite treatment	—
	PCG-6P-2	600	220	Resin	—
WIDER2 [W-200]	PC-4	400	180	Aluminum	—
W-77	PCG-6P-3	600	227	Resin	—
Mounting screw on spray gun: G3/8 (male)					
Gravity feed cup (center cup)					
LPH-80	PCG-2D-1	150	100	Aluminum	—
	PCG-2P-2	200	100	Resin	With paint filter
WIDER3 [W-300]	KIWAMI3 [W-300WB]	400	158	Resin	—
WIDER4/4L	WS-400/LS-400	600	220	Resin	—
LPH-300	PCG-7D-2	700	250	Aluminum	—
Mounting screw on spray gun: G1/4 (female)					
[LPH-400]	PCG-6P-M	600	160	Resin	—
[W-400/-400WB]					
Mounting screw on spray gun: M16 x 1.5 (male)					
Pressurized container					
Compatible spray guns	Model	Capacity (mL)	Mass (g)	Main material	Maximum operating pressure (MPa)
Pressure feed spray guns					
Paint hose connector: G3/8 (male)	PC-18D	2,000	1,250	Aluminum	0.34
Paint hose connector: G1/4 (male)	PC-18DT (For water-based paint)	2,000	1,200	Aluminum + fluorine inner coating	0.34
	PC-18DM (With agitator)	2,000	1,920	Aluminum	0.34
WIDER1/1L [W-101/LPH-101]	PC-17R	400	564	Aluminum	0.20
LW1 [LW-10B/-18B]					
W-71,SGD-71					
Mounting screw on spray gun: G1/4 (male)					
WIDER2/2L [W-200/LPH-200]	PC-19R	1,000	830	Aluminum	0.27
W-77					
Mounting screw on spray gun: G3/8 (male)					
HW-2001/-2003	PC-19B	1,000	470	Aluminum	0.49
Mounting screw on spray gun: M16 x 1 (female)					

Resin lid for aluminum cups PCPL-4

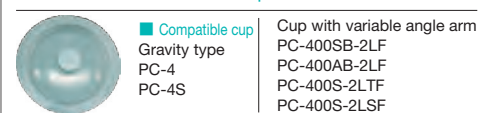

Compatible cup: Cup with variable angle arm
Gravity type: PC-4, PC-4S

Mounting screw on spray gun: G1/4 (male)

Mounting screw on spray gun: G3/8 (male)

Pressurized paint tank

Includes a manual or automatic agitator to prevent paint precipitation. Available in various sizes from 10 to 80 L capacity.

* For more information, refer to the Paint Supply and Coating System Equipment catalog.



PT-20DM (with automatic agitator)

Diaphragm paint pump

Simplifies paint feeding while reducing workloads; simplifies paint color changeovers or replenishment—simply place the suction inlet inside the paint can.

* For more information, refer to the Paint Supply and Coating System Equipment catalog.



DPS-90E

Handy type paint pump

- A paint pump with a 5 L hopper for small-volume painting applications
- Easy to carry. (Weights 8 kg)
- Reciprocal type with no pulsation ensures consistent paint flow.
- For small-volume painting applications involving metal, resin, or wood
- For specific color painting on lines handling metal, resin, or wood materials.
- For painting applications requiring mobility (e.g., shutter or interior painting).

* For more information, refer to the Paint Supply and Coating System Equipment catalog.



HDP-705C

Joints and Hoses

Air Joints

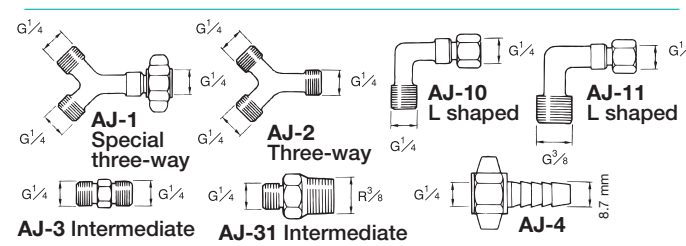

Air Valve

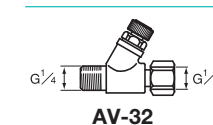

Urethane Air Hose Joints

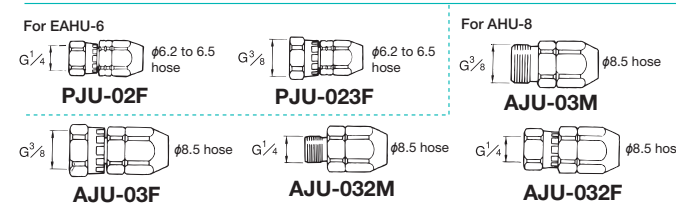

* Use AJU-02F/AJU-02M joints for former AHU-6 urethane air hoses.

Quick Joints for Air (*1)

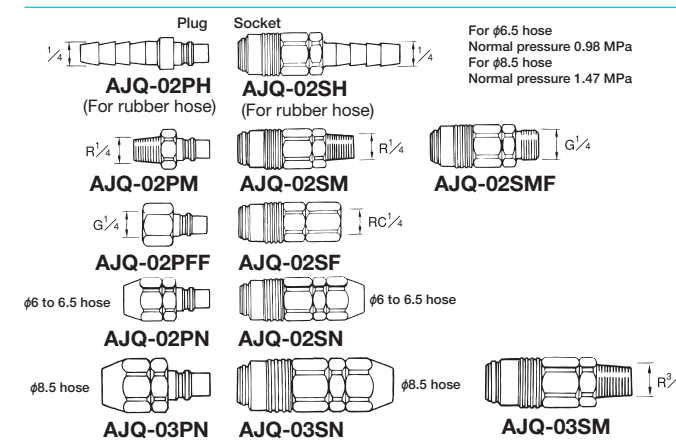

(*1) ● For use with air hoses only. Never use with paint hoses.
● If a ground wire is not used, the joint can be connected in a conventional manner without drawing out the ground wire. However, hoses should be labeled appropriately to avoid mistaken use of hoses with a ground wire and hoses without a ground wire.

Air Hoses (*2)

Model	Material	Inner dia. × Outer dia. × Length	Max. operating pressure
EAHU-620		φ6.2 × φ9.3 × 20 m	
EAHU-630		φ6.2 × φ9.3 × 30 m	
EAHU-650	Urethane with ground wire	φ6.2 × φ9.3 × 50 m	
EAHU-6100		φ6.2 × φ9.3 × 100 m	
EAHU-820		φ8.5 × φ12 × 20 m	1.47 MPa
EAHU-8100		φ8.5 × φ12 × 100 m	
AHU-820B		φ8.5 × φ12 × 20 m	
AHU-830B	Urethane	φ8.5 × φ12 × 30 m	
AHU-850B		φ8.5 × φ12 × 50 m	
AHU-8100B		φ8.5 × φ12 × 100 m	

CAUTION Precautions when using air hoses with ground wire (*2)

- These hoses include a ground wire, but the connected devices must be grounded.
- Never use as air hoses for supply pumps used with low-resistance paint static spraying units or insulated bases whether or not the ground wire is used. In such cases, use a urethane air hose (AHU-8) or paint hose (PHU/PHN) as the air hose.
- When using the ground wire, ground in accordance with the instruction manual and periodically check conductivity using a tester. Never use hoses if they are degraded or have broken wires; replace immediately with a new hose.
- For use as air hoses only. Never use as paint hoses.
- If a ground wire is not used, the joint can be connected in a conventional manner without drawing out the ground wire. However, hoses should be labeled appropriately to avoid mistaken use of hoses with a ground wire and hoses without a ground wire.

Paint Joints

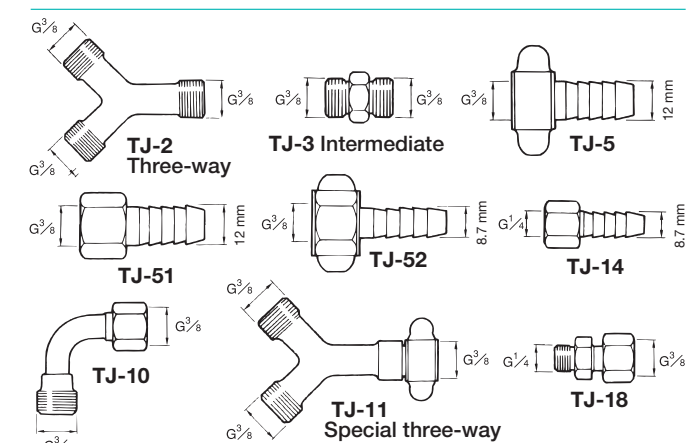

TJ-15 For airless spray guns (with high-pressure paint)
TJ-16 For airless spray guns (with high-pressure paint)
TJ-17 For airless spray guns (with high-pressure paint)

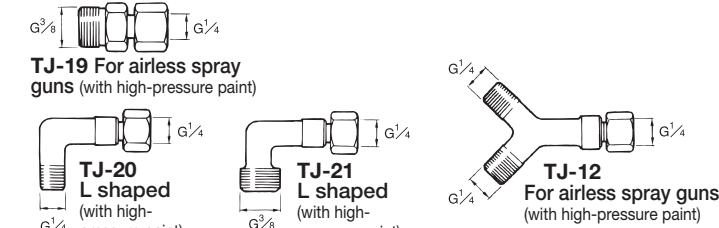

Paint Hose Joints

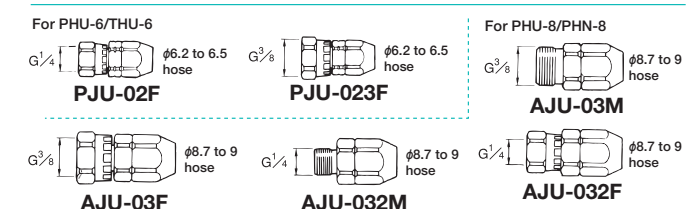

Paint Quick Joints

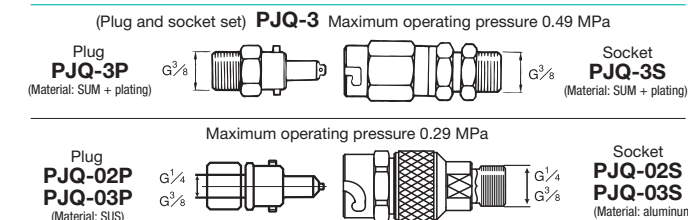

Paint Hoses (*3)

Model	Material	Inner dia. × Outer dia. × Length	Max. operating pressure
PHU-620		φ6.2 × φ9.3 × 20 m	
PHU-6100	Urethane	φ6.2 × φ9.3 × 100 m	0.69 MPa
PHU-820		φ8.7 × φ12 × 20 m	
PHU-8100		φ8.7 × φ12 × 100 m	
PHN-620		φ6.5 × φ9.5 × 20 m	
PHN-6100	Nylon	φ6.5 × φ9.5 × 100 m	0.69 MPa
PHN-820		φ8.9 × φ12.1 × 20 m	
PHN-8100		φ8.9 × φ12.1 × 100 m	
PHF-620	Urethane with fluorine-based inner lining	φ6.5 × φ9.5 × 20 m	
PHF-6100		φ6.5 × φ9.5 × 100 m	0.69 MPa
PHF-820		φ8.9 × φ12.1 × 20 m	
PHF-8100		φ8.9 × φ12.1 × 100 m	
THU-620	Urethane (twin)	φ6.2 × φ9.3 × 2 × 20 m	
THU-6100		φ6.2 × φ9.3 × 2 × 100 m	0.69 MPa

* The THU-6 Series twin hoses for air feature orange threads and have the model printed on them.

CAUTION Precautions on paint hose selection (*3)

- Do not use urethane paint hoses (PHU/THU) with highly-dissolving or reactive paints or thinners such as ketone-based solvents, 2K reaction paints, or urethane-based paints. These products may cause the hose to split, allow paint to spray out, and generate various hazards. Use nylon paint hoses (PHN) instead.

Safety Precautions

■ Use precautions

1. Do not use the products shown in this catalog for the following purposes:
 - ① Manufacture of orally-administered products such as food or medicine
 - ② Applications for which product internal corrosion may cause harm to humans, animals, or wildlife
2. Carefully read the relevant instruction manuals before use.
3. Do not attempt to modify products. Modification may impair performance or result in failure.

- The products described in this catalog are intended for use in Japan. When exporting products purchased in Japan overseas, check in advance to confirm that they comply with applicable regulations and safety standards within the corresponding country.
- The specifications provided in this catalog are subject to change without notice to reflect product improvements.
- The photos and information provided in this catalog may differ from the actual products due to specification changes.

■ Inquiries

SUSTAINABLE DEVELOPMENT GOALS



For general paint users



For automotive repair users

 **ANEST IWATA Corporation**

<https://www.anest-iwata.co.jp/>

Official website

 **Active** with Newest Technology



Printed in Japan CAT No.CT-99987011-00 2023.2 NP.0★0

- This catalog uses FS Youths coated paper.
A portion of the funds set aside to create and publish this catalog will be donated to mental care and educational support programs for orphans of the Great East Japan Earthquake.
- This catalog is made from raw materials from properly managed FSC® certified forests and other managed sources.
- This catalog is printed using ink that is free of volatile organic compounds.
- The specifications provided in this catalog are subject to change without notice to reflect product improvements.
- The photos and information provided in this catalog may differ from the actual products due to specification changes.

