

AUTOMATIC SPRAY GUNS



APPLICATIONS FOR GENERAL INDUSTRY

Active with Newest Technology

TO ALL PAINTING INDUSTRIES

The intangibles built into each ANEST IWATA automatic spray gun



Consistency, durability, and quality are vital qualities for industrial coating products. Consistency means minimizing individual differences and variations between lots; durability denotes suitability for extended use backed by one million needle on/off tests; while quality refers to advanced performance characteristics represented by high atomization. Over a million ANEST IWATA automatic spray guns have been shipped worldwide, all resulting from our mission to ensure customer satisfaction by creating products that embody ANEST IWATA characteristics.

The GFA Series products, which are designed to pursue superior quality paint surface, as well as the WRA Series products, represented by WRA-M200 and WRA-M50, offer pressure reductions achieved by high atomization efficiency. Improved coating efficiency reduces the amount of paint used, which in turn not only reduces VOC emissions, but helps reduce CO2 emissions (through reduced compressor pressure).

We're continuing to design and manufacture spray guns to meet changing needs, including spray guns compatible with increasingly diverse applications and improvements in paint technology. Beyond the pursuit of quality, we're working to help achieve the UN's SDGs through products that promote a sustainable recycling-oriented society and meet other social needs. Our lineup of spray guns support low-VOC, water-based, and other environmentally-friendly paints; our research and development efforts emphasize environmental goals.

Automatic coating with automated spray guns allows the continuous and even application of paint coats. This can minimize the potential for human error and increase quality, providing higher productivity as well as cost reductions through labor saving and manpower saving. ANEST IWATA offers a wide range of automatic spray guns for nearly any application. This range of products allows customers to select the ideal product to meet their needs.

ANEST IWATA's line of optimal spray guns meets the ever diversifying range of potential applications and evolving paint technology. In an industry where further diversification is anticipated, the fast and efficient manufacture of industrial products that can ensure consistency under virtually any conditions is an essential for painting applications.

ANEST IWATA's lineup of automatic spray guns includes models suitable for various applications and environments. We're committed to responding to customer demand for high quality and efficient product manufacturing now and into the future.

AUTO SPRAY GUNS LINE UP

FOR PAINTS

Automatic Spray Guns for Paints



FOR LIQUIDS

Automatic Spray Guns for Liquids



SPECIALTY PRODUCT

Special Purpose Automatic Spray Guns



CONTENTS

1 FOR PAINTS Automatic Spray Guns for Paints

- **General purpose type**
WIDER1A, WIDER2A pp. 7-8
Standard automatic spray guns ideal for a wide range of workpieces and materials, including metal, resin, wood, and furniture
- **Standard type**
SGA-3 p. 9
Compact design automatic spray gun compatible with all kinds of automated equipment
- **High performance type**
WRA-101, WRA-200, LRA-200 p. 10
The most common high performance type automatic spray gun. Ideal for a wide range of workpieces, including metal, resin, wood, and furniture.
- **GFA-200** pp. 11-12
Ultimate large-scale automatic spray gun specifically designed to minimize unevenness. This model is ideal for high quality resin paint spraying using low discharge rates (30 to 100 mL/min).
- **WRA-M50** p. 13
Offers close-range spraying capability and low air consumption combined with wide pattern spraying required for heightened rotary painting efficiency.
- **WRA-M200** p. 14
Ideal for a wide range of applications, including fixed-spindle painting, as well as painting robots, this model is specifically designed for metal, resin, and high quality resin painting (automotive interiors).
- **High performance type, electrostatic**
E-A, EBG pp. 15-16
Relies on electrostatic effects to improve coating efficiency and reduce both the amount of paint used and work times.
- **Electrostatic powder**
EP-AG10H, EP-MU10-D1S12 p. 17
Electrostatic powder coating virtually eliminates VOC emissions to minimize both human and environmental hazards.

2 FOR LIQUIDS Automatic Spray Guns for Liquids

- **Mold release agent (standard type / general purpose type [special])**
TOF-5B/TOF-6B pp. 21-22
- **Mold release agent (round spraying only, standard type / general purpose type [special])**
TOF-5RB/TOF-6RB pp. 21-22
- **Adhesive (general purpose type)**
COG-A200 p. 23
- **Adhesive (high performance type)**
COG-R200 p. 23
- **Adhesive (two-part mixture) (general purpose type)**
WA-200-S6 p. 24
- **Glaze (general purpose type)**
ZP2-A p. 25

3 SPECIALTY PRODUCT Special Purpose Automatic Spray Guns (For paint/liquid spraying)

- **Inner surface spraying, pinpoint spraying (single-side angle, general purpose type)**
RK1-A06-12180/A05-09150/A05-0690 p. 27
- **Marking spraying (airbrushing, high performance type)**
AS-80-001 p. 28
- **For spraying with minimal scatter (air guard) (round spraying only, general purpose type)**
TOF-6RB-S2 pp. 29-30
- **For spraying with minimal scatter (air guard) (round spraying only, high performance type)**
AS-30-111 pp. 29-30
- **For spraying with minimal scatter (ultra compact, high performance type)**
AS-80-011/-013 p. 31

4 PAINTING EQUIPMENT Supply Equipment / Related Products

Diaphragm pumps, pressurized stainless steel tanks, accessories, etc. ... P.33

SYSTEM Automatic spray gun connection system diagram

● Standard type automatic spray guns (SGA-3, TOF-5B)

These automatic spray guns combine the spraying air and piston operation air to enable spraying with a single three-way solenoid valve (in practice, use with a two-way solenoid valve is also possible). Note that these models require at least 0.35 MPa of air pressure due to the need to drive the piston. This means these spray guns are not suitable for subtle painting or low pressure spraying. Pattern widths can be adjusted by turning the knob manually.

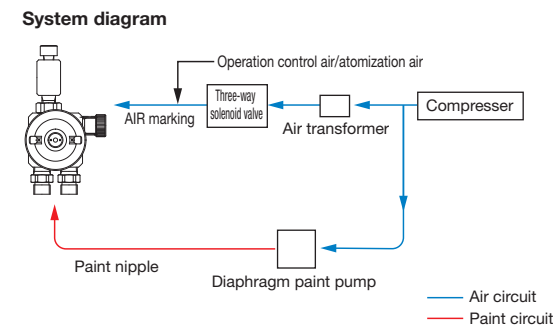

● General purpose type automatic spray guns (e.g., WIDER1A, WIDER2A)

Products in this series feature internal air valves that control the spraying air in conjunction with the operation control air to allow spraying with a single three-way solenoid valve. (See the diagram to the right.) Atomization air can be left on to allow spraying without the need to set up a complex system. Note that remote control is not possible with these products; patterns must be manually adjusted by turning the pattern adjuster.

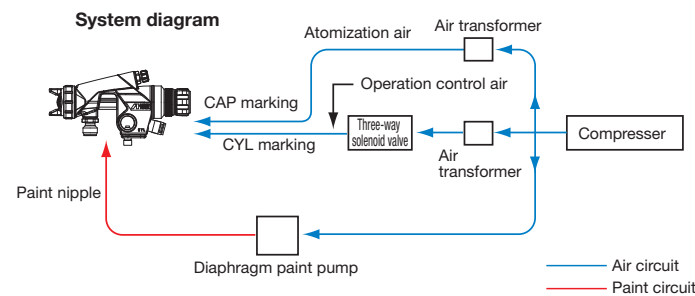





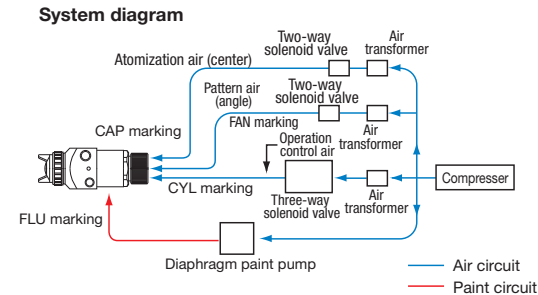







● High performance type automatic spray guns (e.g., WRA-101, WRA-200, GFA-200)

These automatic spray guns permit independent control of atomization air and pattern air (internal air valves not included). The pattern width can be varied remotely when used for tracking painting with a robot, reducing overspray and paint waste. Another key feature is compatibility with paints and other liquids that tend to be precipitate out of solution, such as metallic paints, owing to the spray gun's internal configuration that allows the paint to recirculate within the gun. (* Certain models are not equipped with internal recirculation functionality.)



PICTGRAM Explanation of pictograms on product pages

- | | | |
|--|---|--|
|  <p>Manifold
This automatic spray gun is designed to allow the stay attachment (manifold) to be detached from the main automatic spray gun unit.</p> |  <p>Stainless steel wetted parts
All parts exposed directly to paint (wetted parts) are made of stainless steel for high durability and compatibility with water-based paints.</p> |  <p>Paint recirculation
Allow recirculation of the paint within the spray gun to minimize precipitation of pearl and metallic constituents.</p> |
|  <p>Micro paint adjustment
Micro paint adjustment feature (micro paint adjustment knob) allows needle retraction to be adjusted in 0.01 mm steps. This automatic spray gun is recommended for users requiring precise paint discharge adjustments.</p> |  <p>Pattern width remote adjustment
This automatic spray gun allows remote adjustments of pattern widths for use in situations where pattern widths need to be varied while painting is underway.</p> |  <p>Linear pattern
This automatic spray gun is designed to ensure that the pattern width changes in proportion to the degree to which the pattern adjuster is opened.</p> |
|  <p>Dedicated air cap
This automatic spray gun uses a series-dedicated air cap to maximize spray gun performance.</p> |  <p>Low pressure (HVP)
These models offer high atomization even with low pressure air. (See p. 6 and p. 20 for more information.)</p> |  <p>Body alumite treatment
The spray gun body is alumite coated for improved appearance and corrosion resistance.</p> |
|  <p>Body plating
The spray gun body is plated for improved corrosion resistance.</p> |  <p>Small footprint
Compact dimensions (overall length 100 mm or less) allows installation virtually anywhere.</p> |  <p>Up to 300 g
Weighs no more than 300 g to make it ideal even for robot multi-gun configurations.</p> |

FOR PAINTS

Automatic Spray Guns for Paints

1



Automatic spray guns for painting applications
A broad range of products is available to meet customer requirements and applications, configurations,* and discharge range.
The lineup also includes electrostatic spray guns.

* Standard, general purpose, or high performance configurations in the connection system

Automatic Spray Guns for Paints

Automatic Paint Spray Gun Selection Guide

Points to note and comparisons of recommended automatic spray gun products

- ① Select models from the chart below based on parameters such as Solenoid valve and number required, Industry/process, Object size, and Specifications.
 - ② "★" indicates the most recommended model for a particular spray gun body type. ("☆" indicates the second most recommended model. These products offer the greatest versatility and are likely the right choice for those in doubt.) Models with indications in the Comments section are products designed especially for those applications.
 - ③ If you currently use a hand spray gun and are considering automation, refer to the bottom of the table where the hand spray gun model with equivalent performance as the automatic model in that column is listed.
- Note: If the body model is WRA-M200 and the model suffix is "-1201", the product model is WRA-200-1201.

Automatic spray gun air control

The air for automatic spray guns is typically controlled by solenoid valves.

- ① Solenoid valves are used to turn the air on and off.
- ② These are typically either two-way or three-way solenoid valves.

Two-way solenoid valves

These are typically used for the atomization air and pattern air. Their function is to turn the air on and off.

Three-way solenoid valves

These are typically used for operation control air. In addition to turning air on and off, they release compressed air from the exhaust port when shut off. Two-way solenoid valves cannot bleed air pressure remaining in the piston chamber when the operation control air is shut off; this means the needle cannot be returned and the paint will not stop.

Differences between low pressure and general purpose spray guns (types)

Low pressure spray guns are designed so that the air cap, paint nozzle, and main unit construction offer excellent smooth flow characteristics. They can offer high atomization even in the low pressure range (air cap internal pressure of 0.07 MPa or less). Compared to general purpose spray guns, they offer high coating efficiency and reduced paint mist scattering. They also help enhance work environments by extending spray booth maintenance intervals and reducing worker exposure to paint contamination.

* Reduces paint consumption by 20 to 30 % (ANEST IWATA data).

How is paint coating efficiency increased?

- The lower spraying air pressure allows the paint to adhere more readily to the object being sprayed.
- The paint particle size is slightly larger than with general purpose spray guns to suppress the scattering associated with very fine particles and to improve coating efficiency.

Precautions when using low pressure spray guns

Using low pressure spray guns with an inlet pressure exceeding the recommended conditions indicated in the catalog will cause the spray gun to behave in the same way as a regular spray gun; it will not function as a low pressure device. Increasing pressure will gradually eliminate the benefits of using a low pressure spray gun.

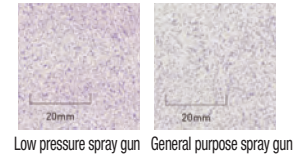

Typical applications are listed here. Applications are also provided in the specifications tables for individual products. Refer to both when selecting products.

⊙ Ideal ○ Suitable * The intermediate coat is the base coat; the final coat is the top coat (e.g., clear)

Automatic spray gun	Spray gun type	General purpose type (internal air valve)										High performance type (without air valve)								Spray gun type		
	Air valve mechanism	Three-way solenoid valve x 1										Three-way solenoid valve x 1, two-way solenoid valve x 2								Air valve mechanism		
Atomization	Solenoid valve and number required	Three-way solenoid valve x 1										Three-way solenoid valve x 1, two-way solenoid valve x 2								Solenoid valve and number required		
	Atomization air flow rate adjustment	✓ (Note: Atomization air and pattern air use the same passages. Changing the air pressure remotely affects both.)										✓								Atomization air flow rate adjustment		
Pattern air	Pattern air flow rate adjustment	✓										✓								Pattern air flow rate adjustment		
	Product image																			Product image		
Body model	Atomization type	General										General								Atomization type		
	Model suffix	-08E2P	-10E1	-10E2P	-13H2	-12G2P	-15K2	-20R2	-25W1	-082P	-122P	-122P	S10C22-08	-084P	S2Bx6-10	-102P	-1202	-1203	N-1206			
High atomization	Recommended! →			★	☆	☆	★			★	☆		★		★		☆		Split nozzle			
	Comments →														Specifically for rotary painting							
Nozzle orifice (φmm)	High atomization	1.0	0.8	1.0	1.0	1.3	1.2	1.5	2.0	2.5	0.8	1.2	1.2	0.8	1.0	1.0	1.2	1.2	1.2			
	Discharge rate range (mL/min)	50 to 150	50 to 150	50 to 100	50 to 200	70 to 250	100 to 500	100 to 270	200 to 400	250 to 500	50 to 150	100 to 500	100 to 500	50 to 150	70 to 200	50 to 150	70 to 200	70 to 200	150 to 300			
Industry/process	Metal	○	○	○	○	○	○	○	○	○	○	○	○	○	○	○	○	○	○	○		
	Resin	○	○	○	○	○	○	○	○	○	○	○	○	○	○	○	○	○	○	○		
Wood/furniture	Intermediate coat	○	○	○	○	○	○	○	○	○	○	○	○	○	○	○	○	○	○	○		
	Final coat	○	○	○	○	○	○	○	○	○	○	○	○	○	○	○	○	○	○	○		
Glaze	For sanitary ware	○	○	○	○	○	○	○	○	○	○	○	○	○	○	○	○	○	○	○		
	Adhesive	○	○	○	○	○	○	○	○	○	○	○	○	○	○	○	○	○	○	○		
Water	Mold release agent	○	○	○	○	○	○	○	○	○	○	○	○	○	○	○	○	○	○	○		
	Water	○	○	○	○	○	○	○	○	○	○	○	○	○	○	○	○	○	○	○		
Object size	Small (up to 60 cm²)	→	→	→	→	→	→	→	→	→	→	→	→	→	→	→	→	→	→			
	Medium (up to 150 cm²)	→	→	→	→	→	→	→	→	→	→	→	→	→	→	→	→	→	→			
Paint viscosity (ANEST IWATA cup / NK-2)	Low viscosity (up to 15 s)	→	→	→	→	→	→	→	→	→	→	→	→	→	→	→	→	→	→			
	Medium viscosity (15 to 25 s)	→	→	→	→	→	→	→	→	→	→	→	→	→	→	→	→	→	→			
Specifications	Body material	Brass (plated)	Aluminum										Aluminum (alumite-coated)				Stainless steel		Aluminum (alumite-coated)		Body material	
	Wetted parts material	Brass, stainless steel	Stainless steel										Aluminum (alumite-coated), stainless steel				Stainless steel		Aluminum (alumite-coated), stainless steel		Stainless steel	
Manifold specifications	· Nozzle material	SUS303	SUS303										SUS303				SUS303		SUS303		· Nozzle material	
	· Needle material	SUS304	SUS420J2										SUS420J2				SUS420J2		SUS420J2		SUS303	
Internal recirculation	Round rod mounting hole diameter	φ10 mm	φ16 mm										φ8.2 mm				φ8.2 mm		φ8.2 mm		Round rod mounting hole diameter	
	Mass	270 g	400 g										325 g				325 g		350 g		600 g	
Other features	When considering automation	—	WIDER1-08E2P	WIDER1-10E1S/G	WIDER1-10E2P	WIDER1-13H2S/G	WIDER2-12G2P	WIDER2-15K2S/G	WIDER2-20R2S/G	WIDER2-25R1S/G	WIDER1-08E2P	WIDER2-12G2P	WIDER2L-12G2P	Special purpose dedicated low discharge rate nozzle		Index cap	Index cap, tool-free construction		—		Other features	
	When considering automation	—	—	—	—	—	—	—	—	—	—	—	—		—	—		—		When considering automation		

1 Automatic Spray Guns for Paints

WIDER1A

WIDER1A

Small



WIDER2A

WIDER2A

Large



General purpose type



General purpose type



This standard long-selling automatic spray gun exemplifies ANEST IWATA versatility. Improvements implemented in July 2021 offer even greater quality and consistency.

Applications

Recommended for painting metal and resin
Products with a nozzle orifice diameter of 1.0 mm or greater are also recommended for use with wood and furniture.

New model offering easier maintenance

The various knobs are tapered with deep grooves to make fine adjustments even easier. Each nipple features a guide at the inlet to facilitate hose connections.

Air cap set

- The thread pitch was changed from 1 mm to 1.5 mm for easier attachment and detachment.
- The new design virtually eliminates air leaks from the air cap cover. Upgraded materials provide greater solvent resistance.

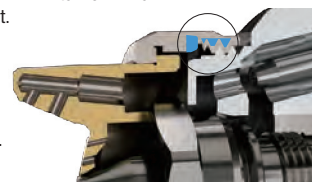

Air valve seat set

Previous models required a specialist tool to remove the valve seat; now this can be removed using a 14 mm box wrench.

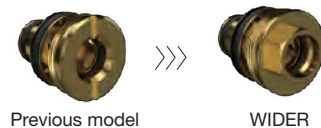

Previous model

WIDER

Paint adjuster

Previous models required a 32 mm box wrench to remove the adjusters; now this can be removed without the use of tools.



Previous model

WIDER

Pattern adjuster with linear response

With the previous pattern adjuster, turning one revolution gave a pattern width of approximately 45%; a 1.5-revolution turn gave a pattern width of approximately 80%; and two revolutions resulted in a fully opened state with a pattern width of approximately 100%. The newly developed pattern adjuster provides more intuitive linear response adjustments, with one revolution resulting in a pattern width of approximately 35%; 1.5 revolutions resulting in a pattern width of approximately 50%; and two revolutions resulting in a pattern width of approximately 70%.

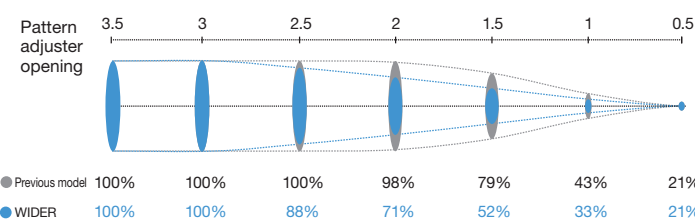

Component interchangeability

The figure to the right indicates components that are not interchangeable between the earlier WA-101 and the current WIDER1A and the earlier WA-200 and the current WIDER2A.

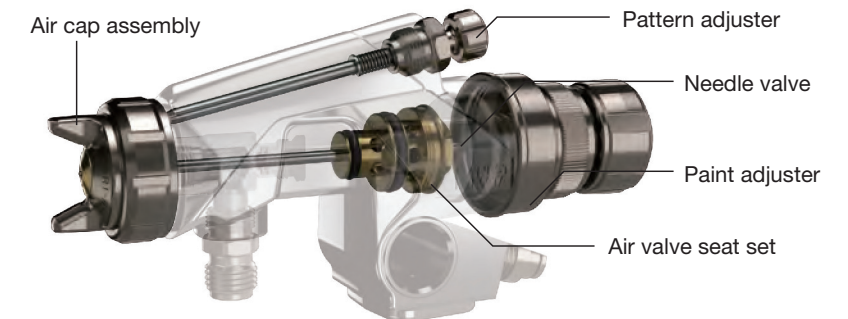

Needle valve seal set

Backed by a track record of more than 20 years, most of ANEST IWATA's hand spray guns and automatic spray guns employ a needle valve seal of the same construction and materials. The seals for stopping the paint are made of a special composite material combining fluororesin (red) and rubber (black). The fluororesin blocks the paint, while the rubber ensures durability. The seals are arranged in two rows so that even if the first seal starts to leak, the second will stop the paint. Ongoing minor improvements of materials have continually improved the already remarkable durability.

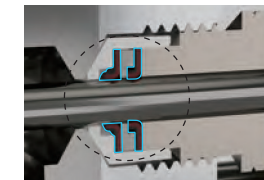

Air connection method

The WIDER models feature push-on joints (atomization air: $\phi 8$ mm, operation air: $\phi 6$ mm) as standard. The air nipples provided with the products must be fitted for those using existing ANEST IWATA joints.



Reference drawing (mm)

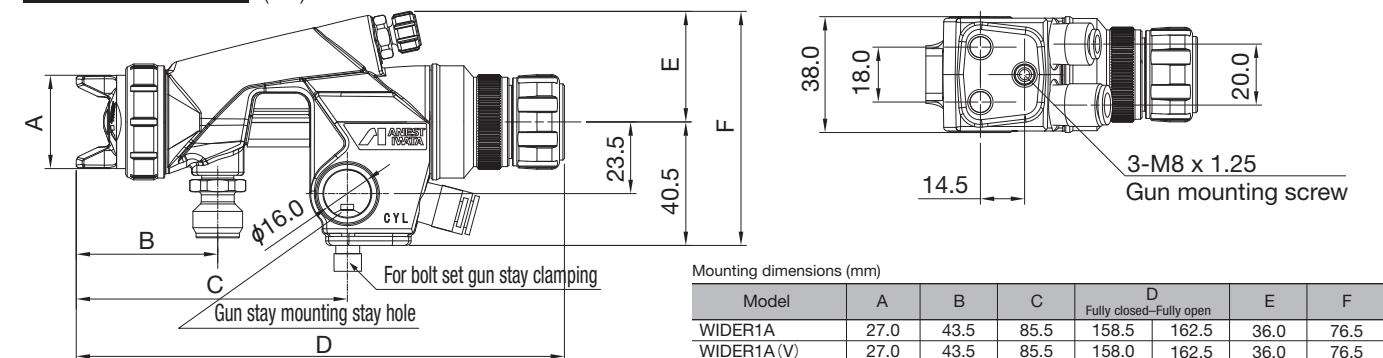

Specifications

	Previous model	Model	Type of feed	Nozzle orifice ϕ mm	Recommended conditions			Pattern width mm	Air cap model	Spray pattern	Mass g
					Spraying air pressure*1 MPa	Paint discharge rate mL/min	Air consumption L/min				
Small	WA-101-082P(V)	WIDER1A-08E2P(V)	Pressure	0.8	0.29	150	270	190	WIDER1-E2P	Round/flat spraying	425
	WA-101-102P(V)	WIDER1A-10E2P(V)		1.0		200	270	220			
	WA-101-101P(V)	WIDER1A-10E1(V)	Pressure (gravity/suction possible)	1.0		100	90	140	WIDER1-E1		
	WA-101-132P(V)	WIDER1A-13H2(V)		1.3		250	260	230	WIDER1-H2		
	WA-101R-05P(V)	WIDER1A-05R(V)	Pressure	0.5		20	40	35	WIDER1-05R		
Large	WA-200-122P(V)	WIDER2A-12G2P(V)	Pressure	1.2	0.29	500	530	400	WIDER2-G2P	Round/flat spraying	445
	WA-200-152P(V)	WIDER2A-15K2(V)		1.5		270	330	340			
	WA-200-202P(V)	WIDER2A-20R2(V)	Pressure (gravity/suction possible)	2.0		400	360	320	WIDER2-R2		
	WA-200-251P(V)	WIDER2A-25W1(V)		2.5		500	360	330	WIDER2-W1		

* Spraying air pressure refers to the spray gun inlet pressure when the piston is pulled and spraying air is flowing. * Models with the suffix "V" offer infinitely variable paint adjustment.
 ● The spray distance is 200 mm for WIDER1A and 250 mm for WIDER2A.
 ● The connector diameters are as follows: WIDER1A: Atomization air $\phi 8$ mm tube, operation air $\phi 6$ mm tube, paint G1/4 (male); WIDER2A: Atomization air $\phi 8$ mm tube, operation air $\phi 6$ mm tube, paint G3/8 (male)
 ● Paint viscosity: 20 s / NK-2 ● Compressor requirements: WIDER1A: 1.5 to 2.2 kW, WIDER2A-12G2P: 5.5 to 7.5 kW, -15K2: 2.2 to 3.7 kW, -20R2: 3.7 to 5.5 kW, -25W1: 5.5 to 7.5 kW

1 Automatic Spray Guns for Paints

SGA-3

Standard type

Compact automatic spray gun suitable for mounting on all kinds of automated equipment (overall length 56 mm, overall width 62 mm, overall height 80 mm, 270 g). The clean design allows operation and spraying using a single three-way solenoid valve.

Many customers such as assembly manufacturers mount multiple spray guns on automated or labor-saving equipment.

Applications	Recommended for painting metal, wood, and furniture. As well as painting, they are also recommended for spraying mold coating agents, anti-sputter agents, water, oil, adhesives, deodorizers, and lubricants.
---------------------	--



Reference drawing (mm)

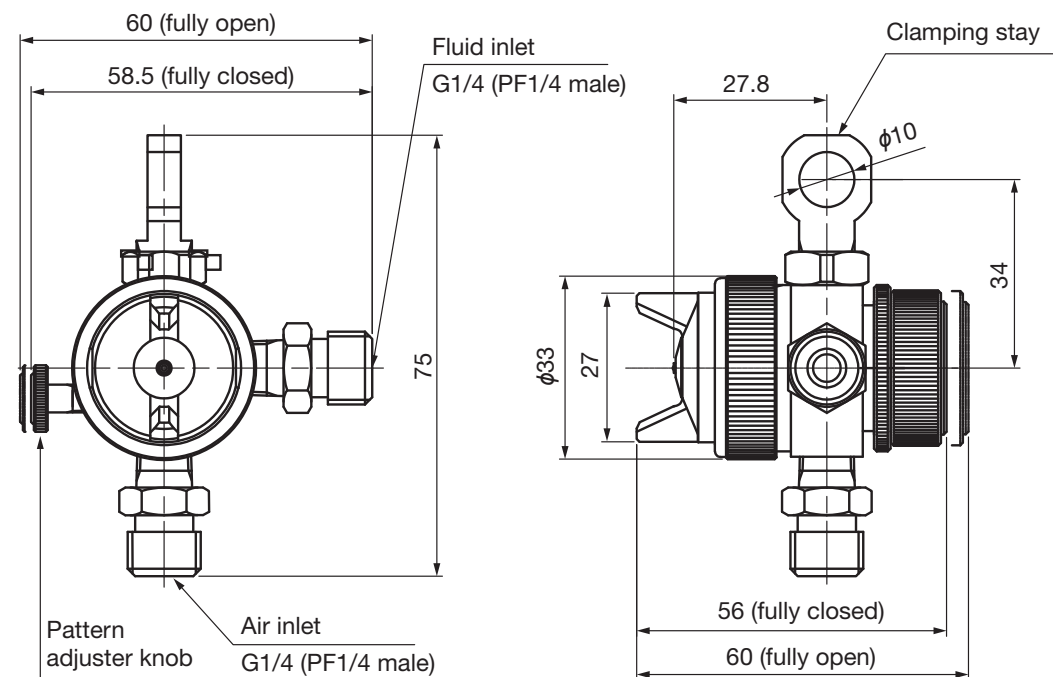

Specifications

Model	Type of feed	Nozzle orifice φmm	Recommended conditions			Air consumption L/min	Pattern width mm	Air cap model	Mass g
			Spraying air pressure* ¹ MPa	Air cap internal pressure MPa	Paint discharge rate mL/min				
SGA-3	Pressure	1.0	0.25	—	—	80	—	SGA-3E1	270

*¹ Spraying air pressure refers to the spray gun inlet pressure when the piston operation air is supplied and spraying air is flowing.
 ● The connector diameters are as follows: Air G1/4 (male), paint G1/4 (male)
 ● Paint viscosity: 20 s / NK-2
 ● Compressor requirements: 0.75 to 1.5 kW

1 Automatic Spray Guns for Paints

WRA-101

Small



WRA-101-082P

High performance type



WRA-200

Large



WRA-200-122P

High performance type



LRA-200

Low pressure, large



LRA-200-122P

High performance type



ANEST IWATA's high performance type automatic spray gun with the most commonly encountered air cap and paint nozzles

Applications Recommended for painting metal, resin, wood, and furniture

Remote pattern width adjustment

Independently controlled center air and angle air features allow remote control of pattern widths while painting is underway and helps prevent overspray.

Allows paint recirculation

Handy for use with paints susceptible to precipitation, such as metallic paints

Compact body

Allows installation in confined spaces for use with automated painting systems and painting robots.

Reference drawing (mm)

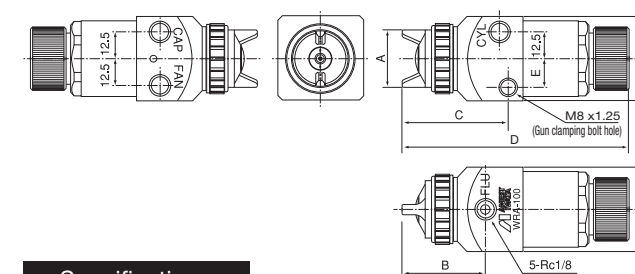

Model	A	B	C	D	E	F	G
WRA-101	27	40	51	109	14.5	40	40
WRA-200	30.5	48	56	111	14.5	40	40
LRA-200	30.5	48	56	111	14.5	40	40

Specifications

Model	Type of feed	Nozzle orifice φmm	Recommended conditions			Air consumption L/min	Pattern width mm	Air cap model	Mass g	
			Spraying air pressure* ¹ MPa	Air cap internal pressure MPa	Paint discharge rate mL/min					
WRA-101-082P	Pressure	0.8	0.26	0.22	—	150	270	190	E2P	290
WRA-200-122P		1.2	0.24	0.26	—	500	530	400	G2P	
LRA-200-122P		1.2	0.14	0.16	0.07	500	500	300	G2	
WRA-101-082PV	Pressure	0.8	0.26	0.22	—	150	270	190	E2P	290
WRA-200-122PV		1.2	0.24	0.26	—	500	530	400	G2P	
LRA-200-122PV		1.2	0.14	0.16	0.07	500	500	300	G2	

*¹ Spraying air pressure refers to the spray gun inlet pressure when the piston is pulled and spraying air is flowing. * Models with the suffix "V" offer infinitely variable paint adjustment.
 ● The spray distance is 200 mm for WIDER1A and 250 mm for WIDER2A.
 ● The connector diameters are as follows: WIDER1A: Atomization air φ8 mm tube, operation air φ6 mm tube, paint G1/4 (male); WIDER2A: Atomization air φ8 mm tube, operation air φ6 mm tube, paint G3/8 (male)
 ● Paint viscosity: 20 s / NK-2
 ● Compressor requirements: WIDER1A: 1.5 to 2.2 kW, WIDER2A-1262P: 5.5 to 7.5 kW, -15K2: 2.2 to 3.7 kW, -20R2: 3.7 to 5.5 kW, -25W1: 5.5 to 7.5 kW

1 Automatic Spray Guns for Paints

GFA-200-084P

Low discharge rate compatible type



GFA200S10C22-08

Lightweight type



GFA200S2BX6-10

Medium discharge rate compatible type

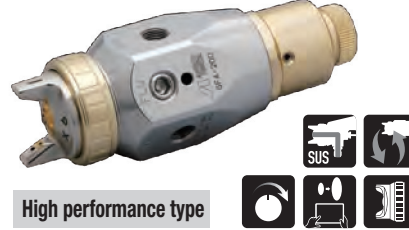

Top-of-the-range ANEST IWATA automatic spray gun models recommended for painting metal and resin

Applications

Recommended for robot painting and spindle painting applications such as for digital cameras and smartphones.

Applications

Recommended for applications involving multiple spray guns mounted on a single painting robot, such as for twin spinning

Applications

Recommended for applications such as laptop PC and automotive resin component mask jig painting and metal mesh painting

Refined unevenness reduction and reduced paint consumption

With traditional cases, thin-coat or high gloss painting with ultra-low discharge conditions often produce unevenness and pattern distortion. ANEST IWATA has painstakingly examined the causes of unevenness and analyzed spray gun air flows in depth to eliminate the causes.

Comparison to conventional spray guns

Painting with a conventional spray gun

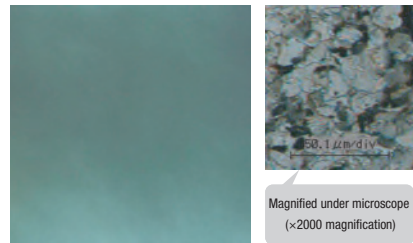

Metal flakes lift up, pigment clumps.

Painting with the GFA-200-084P

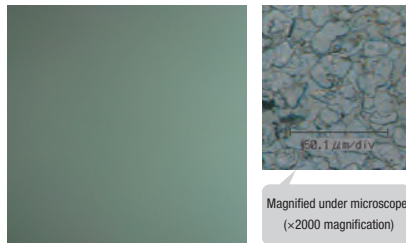

Metal flakes are evenly distributed with no lifting; pigment is well distributed.

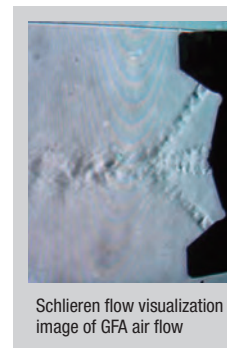

Schlieren flow visualization image of GFA air flow

Painting conditions

- Paint: Paint with metal-like finish
- Discharge rate: 70 mL/min
- No. of passes: 3
- Coating thickness: 6 μm

In most paint lines, this spray gun results in improved finish quality and reductions in paint consumption between 10 and 50 %.
* Reduction in the amount of paint used is largely due to reduction in the number of passes enabled via reduced unevenness, rather than improvement in the coating efficiency of the gun itself.

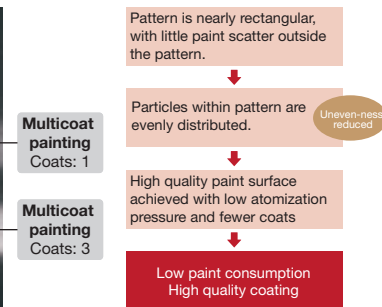
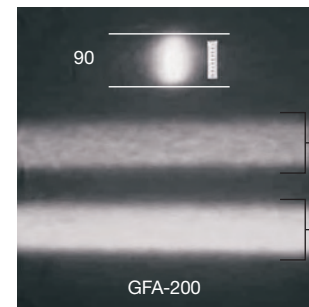
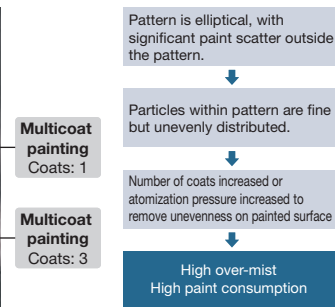
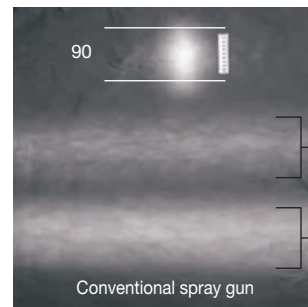

Paint line case studies

① Mobile phone bodies
Tinted clear metallic coating
Paint consumption reduced by 15 to 22 %

② LCD TV frames
Metallic coating
Paint consumption reduced by 25 %

③ Audiovisual equipment components
Metallic coating
Paint consumption reduced by 15 to 25 %

④ Resin components
Metallic coating
Paint consumption reduced by 15 to 45 %

⑤ Automotive exterior corner bumpers
Metal-like coating
Automation of hand spray gun lines

⑥ Automotive exterior rear decorative parts
Pearlescent metallic coating
Cycle times reduced by 50 %

1 Automatic Spray Guns for Paints

Comparison to general purpose spray guns

The GFA Series are spray guns designed specifically to reduce unevenness.

The recent trend in resin-based paints is toward increased brightness and gloss. Paints contain various pigments, such as glass powder and vapor-deposited metals. With demand growing for thin coatings and low discharge rates, painted surfaces are increasingly susceptible to unevenness. Conventional spray guns offer high versatility and produce fine particles but cannot suppress this unevenness.

Reducing unevenness does not entail reducing particle size.

The key lies in ensuring the even distribution of particles within the pattern.

In addition to three standard models, the GFA-200 Series includes models that meet special requirements, including narrow pattern specifications, low air consumption specifications, low pressure specifications, paint clogging prevention specifications, and carbide nozzle seat specifications. For more information, refer to the dedicated GFA Series leaflet.

GFA-200 Series leaflet (Electronic catalog)

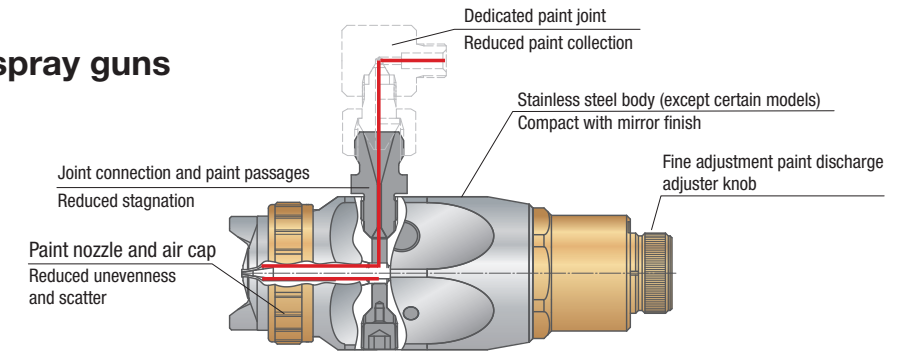

Construction and features

- High density flat pattern
- Entirely stainless steel body (compatible with all types of paint, including water-based paints)
- Paint passage design minimizes paint collection.

Reference drawing

(mm)

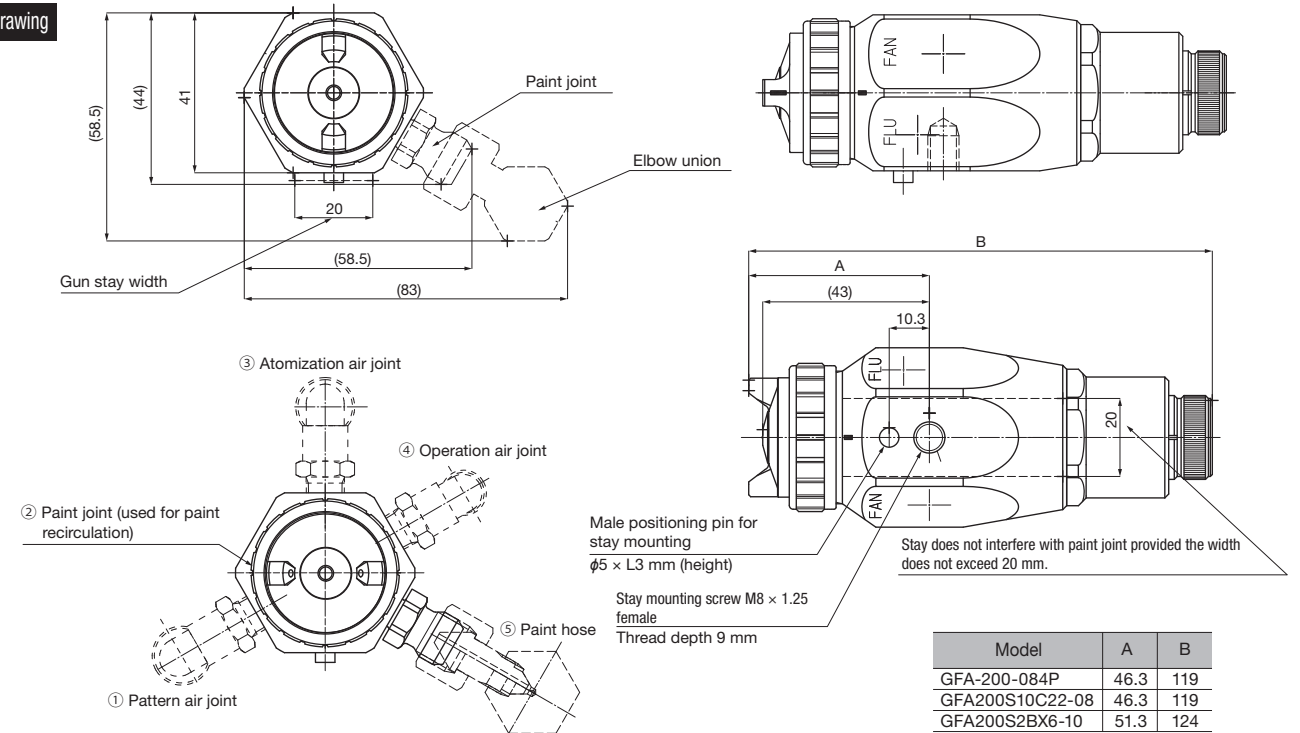

Specifications

Model	Type of feed	Nozzle orifice φmm	Recommended conditions		Air consumption L/min	Pattern width mm	Air cap model	Mass g	Material	
			Spraying air pressure MPa	Paint discharge rate mL/min						
GFA-200-084P	Pressure	0.8	0.11	0.12	30 to 100	190	90	C22	630	SUS
GFA200S10C22-08		0.8	0.11	0.12	30 to 100	190	90	C22	325	Aluminum (alumite-coated)
GFA200S2BX6-10		1.0	0.2	0.25	30 to 100	310	180	X6	630	SUS

- The spray distance is 150 mm for the GFA-200-084P/GFA200S10C22-08 and 200 mm for the GFA200S2BX6-10.
- The connector diameters are as follows for all models: Atomization air Rc1/8 (female), pattern air Rc1/8 (female), operation air Rc1/8 (female), paint G1/8 (female)
- Paint viscosity: all models: 12 s / NK-2
- Compressor requirements: all models: 2.2 to 3.7 kW

1 Automatic Spray Guns for Paints

WRA-M50

Small manifold specifically designed for rotary painting

Optimized for the close-range spraying and reduced air consumption requirements necessary to ensure efficient rotary painting, this produces wide patterns even at close range and with low air consumption.

Applications Recommended for rotary painting of metal and resin

High performance type



Performance comparison to general purpose spray guns

Spray test conditions

Spray gun	Nozzle orifice φmm	Recommended conditions			Air consumption L/min	Pattern width mm
		Spraying air pressure MPa		Paint discharge rate mL/min		
		Atomization	Pattern			
Rotary painting automatic spray gun	1.0	0.15	0.12	100	77	125
General purpose automatic spray gun	0.8	0.18	0.22	100	236	110

● The spray distance for both models is 100 mm. ● Paint viscosity: 12 s / NK-2 (melamine alkyd resin-based paint)

Spray test pattern

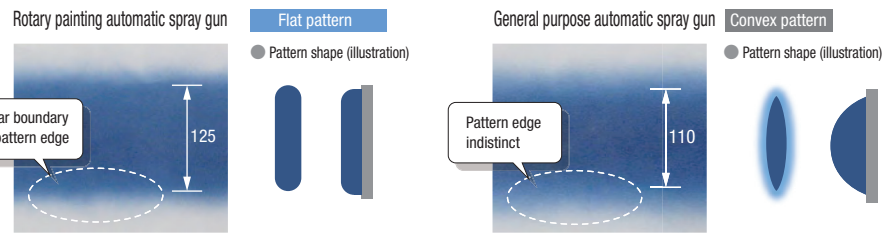

Reference drawing (mm)

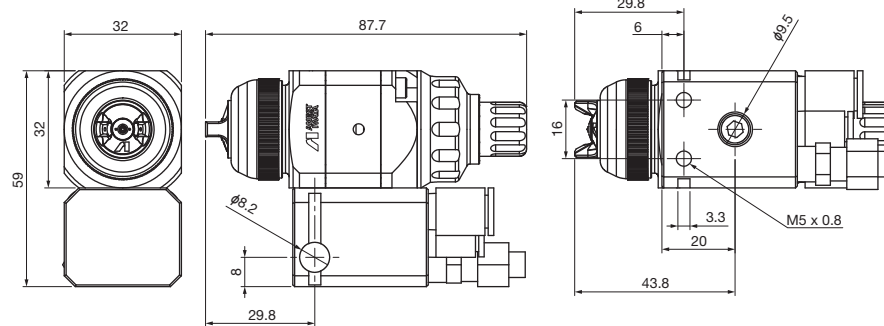

Specifications

Model	Type of feed	Nozzle orifice φmm	Recommended conditions			Air consumption L/min	Pattern width mm	Air cap model	Mass g
			Spraying air pressure*1 MPa		Paint discharge rate mL/min				
			Atomization	Pattern					
WRA-M50-102P	Pressure	1.0	0.12	0.15	50	78	115	WRA-M50-E2	270
			0.15	0.15	75	83	125		
			0.15	0.12	100	77	125		
			0.20	0.13	125	88	120		

* Spraying air pressure refers to the spray gun inlet pressure when the piston operation air is supplied and spraying air is flowing.
 ● The spray distance is 100 mm. ● The connector diameters are as follows: Atomization air φ8 mm tube, pattern air φ8 mm tube, operation air φ6 mm tube, paint φ6 mm tube
 ● Paint viscosity: 10 s / NK-2
 ● Compressor requirements: 1.5 to 2.2 kW

1 Automatic Spray Guns for Paints

WRA-M200

Large manifold

This automatic spray gun offers a high performance large manifold suitable for a wide range of applications. Three caps are available to cover a wide range of discharge rates from approximately 30 mL/min to 300 mL/min.

Applications Recommended for painting metal and resin (including high quality paint final coats)



High performance type



Manifold A manifold refers to a spray gun in which the main automatic spray gun unit is separate from the stay attachment (manifold).

Cap/nozzle/body variations

Various different air caps and nozzle orifice diameters can be combined to allow use across a wide range of commercial applications. The body and manifold are available in a choice of aluminum + alumite or stainless steel specifications to allow use even with water-based paints.

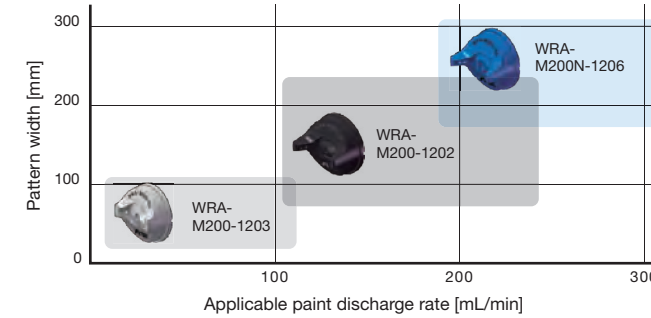

Ease of maintenance

The paint adjuster can be removed without tools.



The design separates the paint path and the piston chamber to make it easy to check the degree of wear of sliding parts such as the needle valve and needle valve seal. The cover on the needle valve seal also functions as a tool for retightening the needle valve seal. In addition to allowing early detection of paint leaks, this allows the needle valve seal to be retightened without disassembly.

High work efficiency

The included spring plunger allows easy alignment of the air cap. As it can be rotated in only one direction, it can be adjusted to the 0 or 90 degree position without the need for visual confirmation. Intermediate adjustments are also possible.

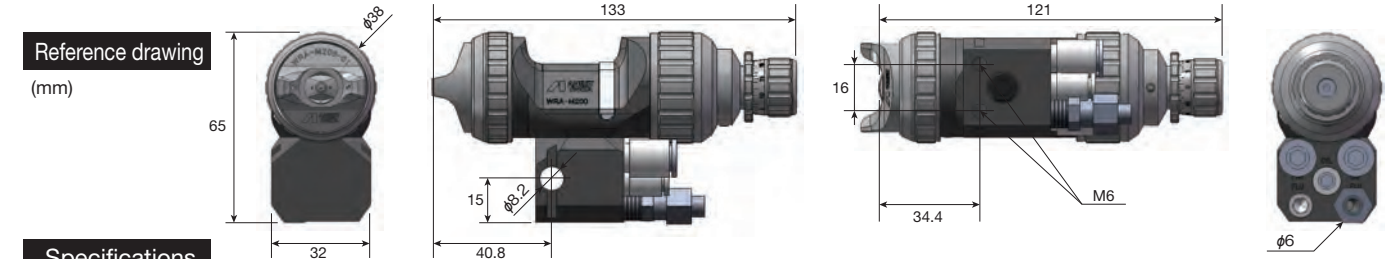

Specifications

Model	Type of feed	Paint nozzle		Recommended conditions			Air consumption L/min	Spray distance mm	Pattern width mm	Air cap model	Mass g	Body/ manifold material
		Orifice φmm	Configuration	Spraying air pressure MPa		Paint discharge rate mL/min						
				Atomization	Pattern							
WRA-M200-1202	Pressure	1.2	Straight	0.23	0.22	200	360	200	180	02	350	Aluminum + alumite
WRA-M200-1203				0.11	0.12	80	200	150	100	03		
WRA-M200N-1206				0.16	0.16	200	430	200	300	06		

* Spraying air pressure refers to the spray gun inlet pressure when the piston operation air is supplied and spraying air is flowing.
 ● The spray distance is 200 mm for the WRA-M200-1202, 150 mm for the -1203, and 300 mm for the N-1206.
 ● The connector diameters are as follows for all models: Atomization air φ8 mm tube, operation air φ6 mm tube, pattern air φ8 mm tube, paint φ6 mm tube
 ● Paint viscosity: WRA-M200-1202: 20 s / NK-2, -1203: 12 s / NK-2, N-1206: 20 s / NK-2

Automatic Spray Guns for Paints

E-A

Large

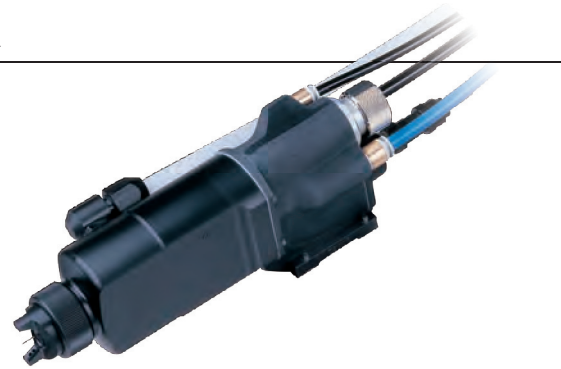

High performance type, electrostatic



EBG

Large

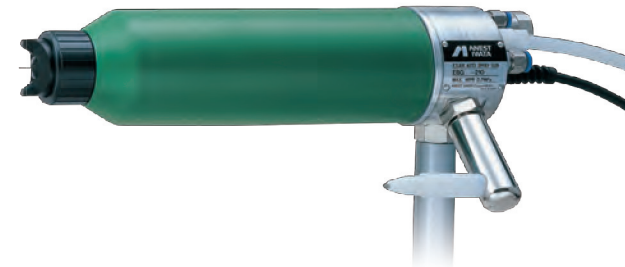

High performance type, electrostatic



Deposition characteristics attributable to electrostatic effects improve coating efficiency by approximately 20 % and reduce both paint consumption and work times by approximately 30 % compared to air-driven spray guns. Coating particle densities are more uniform, reducing unevenness.

Electrostatic painting

Electrostatic painting refers to a painting technology in which a high voltage is output from the spray gun atomizing head to generate an electric field,* which charges the discharged paint to improve coating efficiency.
* This requires the workpiece (object being painted) and peripheral equipment to be electrically grounded.

Applications

Recommended for painting metal, resin, wood, and furniture

* Typically, the resin is virtually non-dielectric and must be treated using a dielectric agent coating, dielectric primer coating, or a grounding jig method.
* Wood typically exhibits electrostatic effects provided the moisture content is at least 10 %.

E-A

Compact and lightweight design

The intermediate seat design turns the paint on and off inside the body, resulting in a compact and lightweight (approximately 1 kg) design ideal for robot mounting.

Ease of maintenance

The paint valve is located inside the spray gun body for ease of maintenance.

Choice of air caps

A selection of three different E-M Series (electrostatic air hand spray gun) air caps is available.

Air cap No.

C1 (clear): Convex pattern general atomization
C5 (base): Flat pattern high atomization
L1 (low pressure): Low pressure atomization

Remotely controllable

The atomization air and pattern air use independent circuits, allowing the pattern width to be adjusted remotely.

EBG

High performance counter electrodes

A high efficiency counter electrode layout gives performance equivalent to -70 kV for an output of -60 kV. Air purging during spraying prevents counter electrode contamination.

Ease of maintenance

A cartridge type paint valve is used for ease of maintenance.

Easy nozzle and electrode replacement

The intermediate seat configuration allows replacement of the paint nozzle and pin electrodes while paint is under pressure.

Easy low-voltage cable replacement

Connectors used for connections between the low-voltage cable and body allow easy low-voltage cable replacement.

Remotely controllable

The atomization air and pattern air use independent circuits, allowing the pattern width to be adjusted remotely.

Reference drawing (mm)

E-A

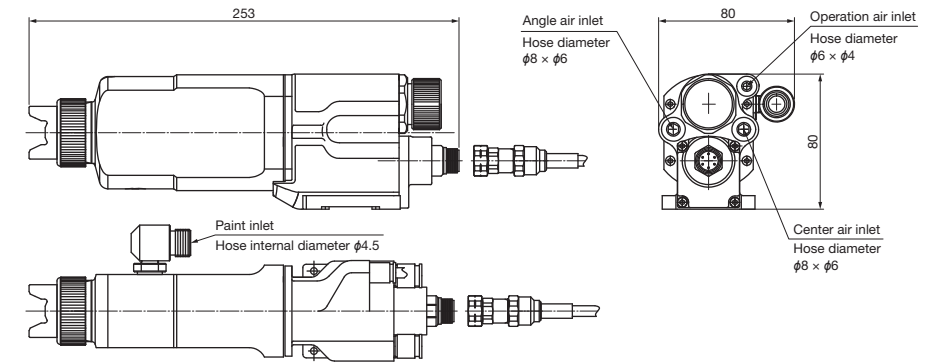

EBG

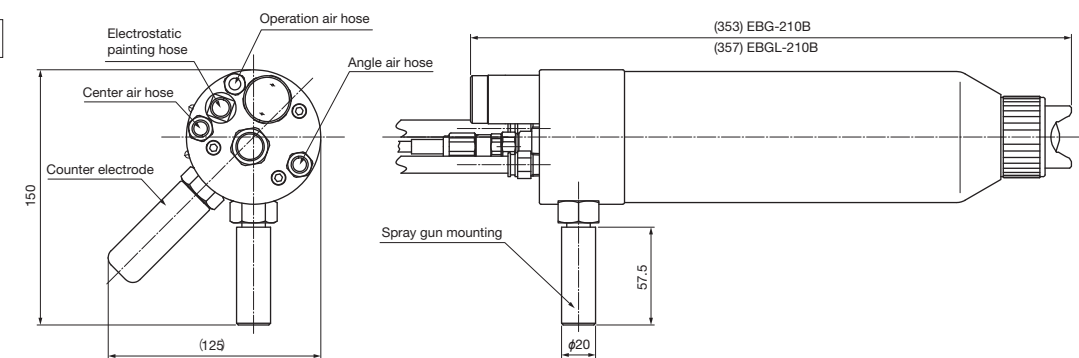

Specifications

E-A

Model	For water-based / low-resistance / general solvent paint	
	E-A10-13C1X	E-A10-13L1X
Type of feed	Pressure	
Atomization method	Convex pattern general atomization	Low pressure atomization
Nozzle orifice	φ1.3 mm	
Spray distance	250 mm	200 mm
Spraying air pressure	Center 0.26 MPa, angle 0.24 MPa	Center 0.12 MPa, angle 0.12 MPa
Air consumption	200 L/min 300 L/min	260 L/min 240 L/min
Paint discharge rate	300 mL/min	160 mL/min
Pattern width	330 mm	240 mm
Input voltage	12 V AC	
Output voltage	-40 kV DC	
Mass	1,000 g	
Low-voltage cable	Standard accessory: 10 m (CEB-11510)	
Paint hose	Standard accessory: Electrostatic paint hose set: Inner dia. φ4.5 mm × 10 m (Paint supply unit cap nut size: G3/8)	
Air hose	Standard accessory: Spraying air hose: Outer dia. φ8 mm × inner dia. φ6 mm × 10 m × 2 (for center/angle) Operation air hose: Outer dia. φ6 mm × inner dia. φ4 mm × 10 m × 1	
Compatible controller	E-SC12B	

* The 15 m and 20 m low-voltage cables are available as options.

EBG

Model	For water-based / low-resistance / general solvent paint	
	EBG-210B	EBGL-210B
Type of feed	Pressure	
Atomization method	Convex pattern general atomization	Low pressure atomization
Nozzle orifice	φ1.5 mm	φ1.8 mm
Spray distance	300 mm	250 mm
Spraying air pressure	Center 0.27 MPa, angle 0.27 MPa	Center 0.17 MPa, angle 0.10 MPa
Air consumption	560 L/min	520 L/min
Paint discharge rate	300 mL/min	
Pattern width	370 mm	300 mm
Input voltage	12 V AC	
Output voltage	-60 kV DC	
Mass	2,100 g	
Low-voltage cable	Standard accessory: 10 m (CEB-11510)	
Paint hose	Standard accessory: Electrostatic paint hose set: Inner dia. φ4.5 mm × 10 m (Paint supply unit cap nut size: G3/8)	
Air hose	Standard accessory: Spraying air hose: Outer dia. φ8 mm × inner dia. φ6 mm × 10 m × 2 Operation air hose: Outer dia. φ6 mm × inner dia. φ4 mm × 10 m × 1	
Compatible controller	E-SC12BH	

* The 15 m and 20 m low-voltage cables are available as options.

E-SC12B/BH Electrostatic controller

Intelligent controller to maximize the performance of electrostatic spray guns

Shield wire failure detection Patent No. 3490255 Metal bridge abnormality avoidance function Patent No. 3335937

Major protection and safety features

- **Ground fault detection**
Detects defective electrostatic controller main unit ground connections.
- **Shield wire failure detection**
Detects failure of the low-voltage cable shield wire.
- **Overcurrent abnormality detection**
Detects painting currents of 80 μA or more (default value).
- **Timeout detection**
Detects a continuous charge signal lasting more than two minutes.
- **Metal bridge abnormality avoidance function**
Function prevents overcurrents due to the interconnection of aluminum flakes dispersed within metallic paint due to electrostatic effects.



Model	E-SC12B/E-SC12BH
Input voltage	100 to 120 V AC 50/60 Hz single phase (as shipped) (Setting can be changed to 200 to 240 V single phase)
Output voltage	Max. 12 V AC (electrostatic controller alone)
Output current	Max. 80 μA (electrostatic gun discharge current)
Power consumption	Approx. 35 W
Dimensions	Overall length 160 mm × overall width 220 mm × overall height 130 mm
Mass	Approx. 3.1 kg
Charge on/off mechanism	Air flow switch method (air joint in/out size: G1/4 male)
Max. operating air pressure	Max. 0.68 MPa

* A code signal is required to turn the charge on/off when using an automatic spray gun.

1

Automatic Spray Guns for Paints

EP-AG10H

Electrostatic powder coating



This series allows powder spraying when the spray gun and unit are used together. Electrostatic powder coating does not produce solvents. The environmentally-friendly product generates no VOCs even if the powder is baked.

EP-MU10-D1-S12

Electrostatic powder coating unit



Electrostatic painting

Electrostatic painting refers to a painting technology in which a high voltage is output from the spray gun atomizing head to generate an electric field,* which charges the discharged paint to improve coating efficiency.

* This requires the workpiece (object being painted) and peripheral equipment to be electrically grounded.

Applications

Recommended for painting metal, resin, wood, and furniture

* Typically, the resin is virtually non-dielectric and must be treated using a dielectric agent coating, dielectric primer coating, or a grounding jig method.
* Wood typically exhibits electrostatic effects provided the moisture content is at least 10 %.

Reference drawing (mm)

EP-AG10H

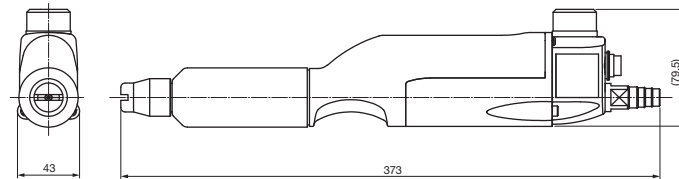

EP-MU10-D1-S12

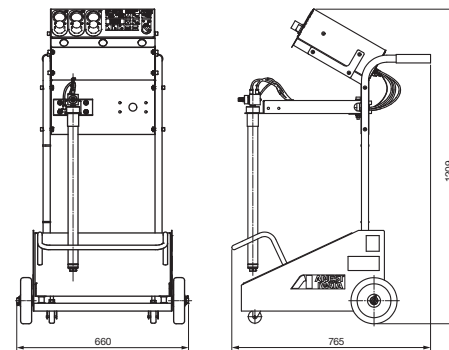

Specifications

EP-AG10H

Model	EP-AG10H	Remarks
Dimensions		Excluding accessories, hoses, and cables
Overall length	373 mm	
Overall width	43 mm	
Overall height	81.5 mm	
Mass	520 g	
Compatible materials (paint)	Powder coating	
Type of feed	Pressure	
Supply air pressure	Max. 0.7 Mpa	
Operating environment	5 to 40 °C, max. 70 %RH	
Spraying nozzle	Flat spraying	
Charging method	Corona discharge (with built-in high voltage generator)	
Input voltage	Max. 24 V (pulse input)	
Input current	Max. 2.1 A	
Output voltage	Max. -100 kV	
Output current	Max. 100 μA	
Power consumption	Max. 50 W	
Compatible painting unit	EP-MU10-D1-S12	(Sold separately)

EP-MU10-D1-S12

Model	EP-MU10-D1-S12
Dimensions	
Overall length	765 mm
Overall width	660 mm
Overall height	1,209 mm
Mass	36.5 kg
Compatible materials (paint)	Powder coating
Input voltage	100 to 130 V AC
Frequency	50/60 Hz
Remote operation	Possible*1
Gun output voltage	Max. 24 V (pulse output)
Gun output current	Max. 2.1 A
Rated output power	50 W
Allowable environmental conditions	-10 °C to +50 °C, 20 to 90 %RH (no condensation)
Max. supply air pressure	0.7 MPa
Max. air consumption	250 L/min*2
Max. discharge rate	300 g/min*2
Compatible powder coating gun	EP-MG10/10L
No. of connected guns	1 gun
Control method	Microprocessor control
Protection features	① Ground abnormality detection ② Shield wire failure detection ③ Output current upper limit setting

*1: Also requires charge signal from external device.

*2: With inner diameter φ13 × 8 m paint hose connected

FOR LIQUIDS

2

Automatic Spray Guns for Liquids



These automatic spray guns are specifically designed for spraying mold release agents, adhesives, and glaze. The WA-200ZP (p. 25) is suitable not just for use with glaze, but for spraying highly abrasive liquids. Select the product to suit the particular liquid being used.

2

Automatic Spray Guns for Liquids

Automatic Liquid Spray Gun Selection Guide

Points to note and comparisons of recommended automatic spray gun products

- Select models from the chart below based on parameters such as Solenoid valve and number required, Industry/process, Object size, and Specifications.
 - "★" indicates the most recommended model for a particular spray gun body type. ("☆" indicates the second most recommended model. These products offer the greatest versatility and are likely the right choice for those in doubt.)
Models with indications in the Comments section are products designed especially for those applications.
 - If you currently use a hand spray gun and are considering automation, refer to the bottom of the table where the hand spray gun model with equivalent performance as the automatic model in that column is listed.
- Note: If the body model is WRA-M200 and the model suffix is "-1201", the product model is WRA-200-1201.

Automatic spray gun air control

The air for automatic spray guns is typically controlled by solenoid valves.

- Solenoid valves are used to turn the air on and off.
- These are typically either two-way or three-way solenoid valves.

Two-way solenoid valves

These are typically used for the atomization air and pattern air. Their function is to turn the air on and off.

Three-way solenoid valves

These are typically used for operational control air. In addition to turning air on and off, they release compressed air from the exhaust port when shut off. Two-way solenoid valves cannot bleed air pressure remaining in the piston chamber when the operation control air is shut off; this means the needle cannot be returned and the paint will not stop.

Differences between low pressure and general purpose spray guns (types)

Low pressure spray guns are designed so that the air cap, paint nozzle, and main unit construction offer excellent smooth flow characteristics. They can offer high atomization even in the low pressure range (air cap internal pressure of 0.07 MPa or less). Compared to general purpose spray guns, they offer high coating efficiency and reduced paint mist scattering. They also help enhance work environments by extending spray booth maintenance intervals and reducing worker exposure to paint contamination.

* Reduces paint consumption by 20 to 30 % (ANEST IWATA data).

How is paint coating efficiency increased?

- The lower spraying air pressure allows the paint to adhere more readily to the object being sprayed.
- The paint particle size is slightly larger than with general purpose spray guns to suppress the scattering associated with very fine particles and to improve coating efficiency.

Precautions when using low pressure spray guns

Using low pressure spray guns with an inlet pressure exceeding the recommended conditions indicated in the catalog will cause the spray gun to behave in the same way as a regular spray gun; it will not function as a low pressure device. Increasing pressure will gradually eliminate the benefits of using a low pressure spray gun.

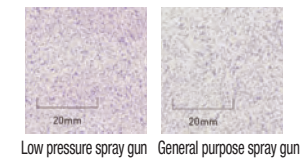

Typical applications are listed here. Applications are also provided in the specifications tables for individual products. Refer to both when selecting products.

☉ Ideal ○ Suitable * The intermediate coat is the base coat; the final coat is the top coat (e.g., clear)

	Target liquid	Mold release agent		Glaze		Adhesive				Target liquid	
		Spray gun type	Standard type	General purpose type (special)	General purpose type	General purpose type	High performance type	Spray gun type			
Automatic spray gun	Air valve mechanism	Three-way solenoid valve x 1		Three-way solenoid valve x 1, two-way solenoid valve x 1		Three-way solenoid valve x 1				Solenoid valve and number required	
	Remote operation	Atomization air flow rate adjustment		(Note: Atomization air and pattern air use the same passages. Changing the air pressure remotely affects both.)		(Note: Atomization air and pattern air use the same passages. Changing the air pressure remotely affects both.)				Atomization air flow rate adjustment	
	Remote operation	Pattern air flow rate adjustment								Pattern air flow rate adjustment	
	Product image										
	Body model	TOF-5B/-5RB		TOF-6B/-6RB		ZP2-A		COG2-A		COG-R200	
	Atomization type	General		General		General		General		General	
	Model suffix	-05/-10/-13/-20		-05/-10/-13/20		-A20		-A25		-18	
	Recommended! →			★(-05)				★		★	
	Comments →	For mold release agent		For mold release agent		For glaze		For glaze		For adhesive only	
	High atomization	✓		✓		✓		✓		✓	
Nozzle orifice (φmm)	0.5/1.0/1.3/2.0		0.5/1.0/1.3/2.0		2.0		2.5		1.2		
Discharge rate range (mL/min)	50 to 150		0 to 600		200 to 760		250 to 760		100 to 150		
Industry/process	Metal	Intermediate coat								Intermediate coat	
	Resin	Final coat								Final coat	
		Intermediate coat								Intermediate coat	
		Final coat								Final coat	
	Wood/furniture	High quality painting intermediate coat								High quality painting intermediate coat	
	Glaze	High quality painting final coat								High quality painting final coat	
		Intermediate coat								Intermediate coat	
	Adhesive	Final coat								Final coat	
		For sanitary ware								For sanitary ware	
	Mold release agent	Max. 200 centipoise								Max. 200 centipoise	
Max. 1,000 centipoise								Max. 1,000 centipoise			
Water	Water-based, solvent								Water-based, solvent		
Object size	Small (up to 60 cm ²)		Small (up to 60 cm ²)		Small (up to 60 cm ²)		Small (up to 60 cm ²)		Small (up to 60 cm ²)		
	Medium (up to 150 cm ²)		Medium (up to 150 cm ²)		Medium (up to 150 cm ²)		Medium (up to 150 cm ²)		Medium (up to 150 cm ²)		
	Large (over 150 cm ²)		Large (over 150 cm ²)		Large (over 150 cm ²)		Large (over 150 cm ²)		Large (over 150 cm ²)		
Paint viscosity (ANEST IWATA cup / NK-2)	Low viscosity (up to 15 s)		Low viscosity (up to 15 s)		Low viscosity (up to 15 s)		Low viscosity (up to 15 s)		Low viscosity (up to 15 s)		
	Medium viscosity (15 to 25 s)		Medium viscosity (15 to 25 s)		Medium viscosity (15 to 25 s)		Medium viscosity (15 to 25 s)		Medium viscosity (15 to 25 s)		
	High viscosity (25 to 35 s)		High viscosity (25 to 35 s)		High viscosity (25 to 35 s)		High viscosity (25 to 35 s)		High viscosity (25 to 35 s)		
Specifications	Body material	Brass (plated)		Aluminum		Aluminum		Aluminum (alumite-coated)		Body material	
	Wetted parts material	Brass, stainless steel		Stainless steel		Stainless steel		Aluminum (alumite-coated), stainless steel		Wetted parts material	
	Nozzle material	SUS303		SUS420J2 + carbide		SUS303		SUS303		Nozzle material	
	Needle material	SUS303		SUS420J2 + carbide		SUS420J2		SUS420J2		Needle material	
	Manifold specifications									Manifold specifications	
	Internal recirculation							✓		Internal recirculation	
	Round rod mounting hole diameter									Round rod mounting hole diameter	
Hand spray gun model with equivalent performance	Mass	320 g		330 g		450 g		420 g		310 g	
	Other features	-		-		-		Straight edge needle		Straight edge needle	
	When considering automation	-		-		-		-		-	
				ZP2-H20	ZP2-H25			COG2-H12	COG2-H18	COG-200-12	COG-200-18

2 Automatic Spray Guns for Liquids (Mold release agent)

TOF-5B/TOF-5RB

Mold release agent



TOF-6B/TOF-6RB

Mold release agent



Standard type

General purpose type (special)

These spray guns and related equipment are designed for use specifically with mold release agent in the manufacture of rubber moldings, resin moldings, die casting, and casting.

The broad-ranging lineup includes wide pattern hand spray guns and automatic spray guns. Using spray guns designed specifically for use with mold release agent and offering the appropriate atomization makes it easier to remove molded products from molds and helps prevent damage to both molded product and molds.

These compact models minimize the required space when mounted on equipment.

Their multipurpose specifications allow use not just with mold release agent, but with liquids such as paint and anti-corrosion oil. Equipped with dedicated caps and nozzles, these products are designed to ensure more efficient application of the target liquid.

Applications	Mold release oil	Lubricating oil	Anti-corrosion oil
--------------	------------------	-----------------	--------------------

Applying mold release agent to die cast machine, rubber, and plastic molds

Applying lubricating oil to cutting machine blades or drive chains

Applying anti-corrosion oil to metal components and steel panels

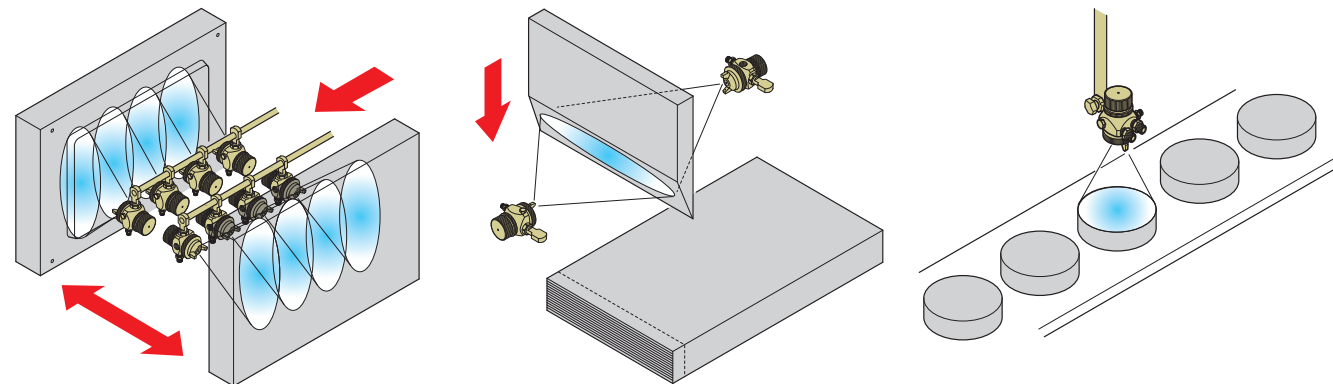

Reference drawing (mm)

TOF-5B/TOF-5RB

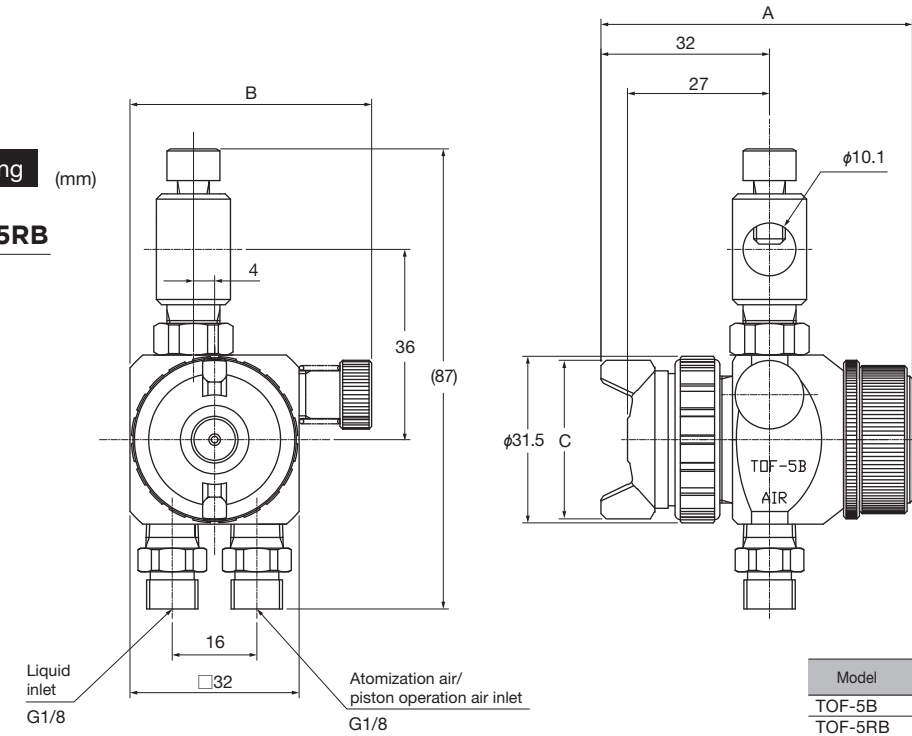

Model	A	B	C
TOF-5B	59 to 63	45.5 to 48.5	30
TOF-5RB	54 to 58	35	25

TOF-6B/TOF-6RB

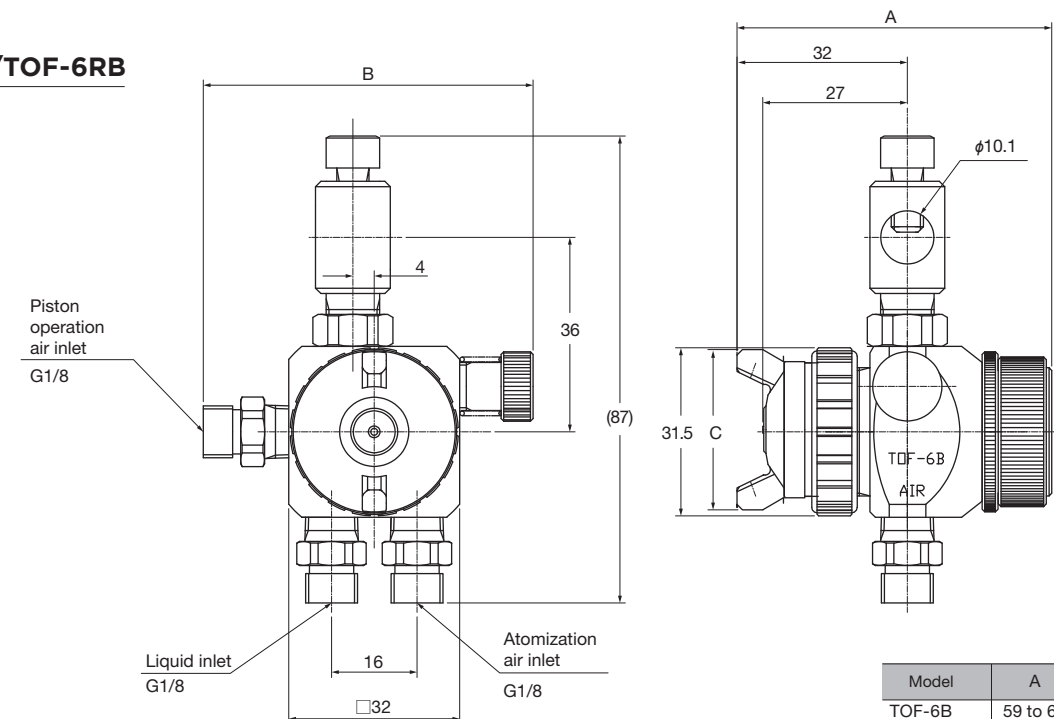

Model	A	B	C
TOF-6B	59 to 63	61.5 to 64.5	30
TOF-6RB	54 to 58	51	25

Specifications

	Model	Type of feed	Nozzle orifice ϕ mm	Recommended conditions		Spraying air pressure			Pattern width		Air cap model	Mass g
				Liquid discharge rate MPa	Air consumption mL/min	Flat spraying L/min	Round spraying L/min	Flat spraying mm	Round spraying mm			
Standard type	TOF-5B/-5RB	Pressure (gravity/suction possible)	-05	0.30	60	60	40	200	50	5	320	
			-10			250	50	250	70	10	300	
			-13			360	55	350	80	13	330	
			-20			600	85	400	90	20	310	
General purpose type	TOF-6B/-6RB	Pressure (gravity/suction possible)	-05	0.30	60	60	40	200	50	5	320	
			-10			250	50	250	70	10	300	
			-13			360	55	350	80	13	330	
			-20			600	85	400	90	20	310	

● The spray distance is 300 mm for all models. ● The connector diameters are as follows for all models: Atomization air G1/8 (male), operation air G1/8 (male), liquid G1/8 (male)
● Compressor requirements: TOF-5B/-5RB/-6B/-6RB: -05/-10 0.75 to 1.5 kW, -13/-20 1.5 to 2.2 kW

2 Automatic Spray Guns for Liquids (Adhesive)

COG2-A

Adhesive



* Photo depicts previous model.



General purpose type

Designed specifically for use with adhesive, these spray guns are capable of spraying liquids with viscosity ranging up to approximately 10,000 MPa·s. They provide high atomization and wide pattern spraying, even with high viscosity adhesives. They are capable of consistent spraying even with high discharge rates.

Applications

Recommended for spraying on to automotive interior components, wood, and rubber components

COG-R200

Adhesive



High performance type

Atomization pattern comparison

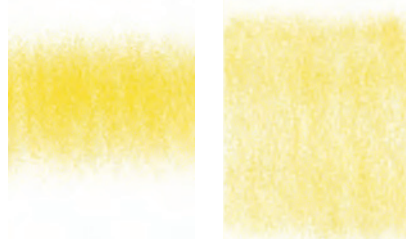

General purpose spray gun spray pattern

COG Series spray pattern

Reference drawing (mm)

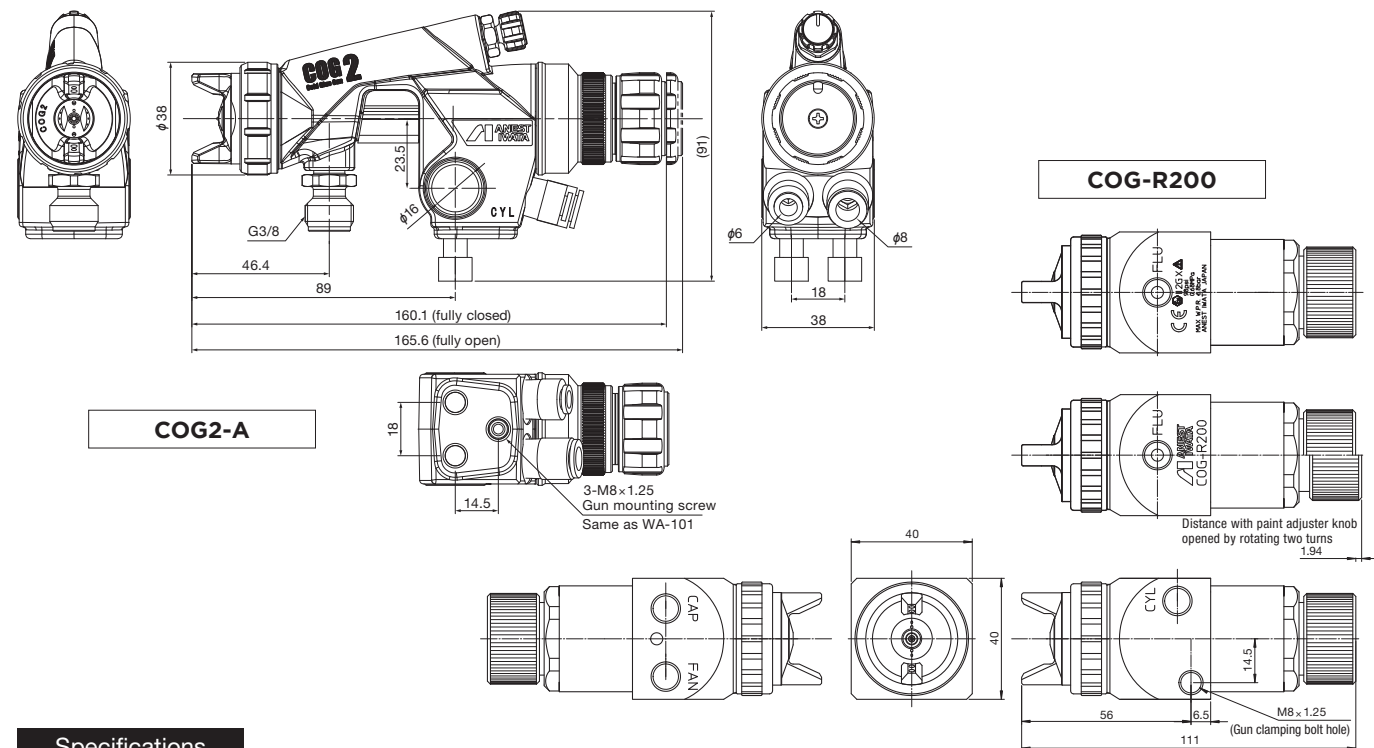

Specifications

	Model	Type of feed	Nozzle orifice φmm	Recommended conditions		Air consumption L/min	Pattern width mm	Air cap model	Mass g	
				Spraying air pressure* MPa	Liquid discharge rate mL/min					
General purpose type	COG2-A	Pressure	12	0.29	—	150	440	265	COG2	420
			18							
High performance type	COG-R200	Pressure	12	0.20	0.15	150	340	265	COG-200	310
			18							

* Spraying air pressure refers to the spray gun inlet pressure when the piston operation air is supplied and spraying air is flowing.
 ● The connector diameters are as follows: COG2-A: Atomization air φ8 mm tube, operation air φ6 mm tube, liquid G3/8 (male); COG-R200: Atomization air Rc1/8 (male), pattern air Rc1/8 (male), operation air Rc1/8 (male), liquid Rc1/8 (male) ● Compressor requirements: all models: 5.5 to 7.5 kW

2 Automatic Spray Guns for Liquids (Adhesive)

ZP2-A

Glaze (abrasive agent)



* Photo depicts previous model.



General purpose type

This spray gun is designed specifically for spraying glaze on sanitary ware (e.g., toilets and washbasins), tableware, and enamel products, etc. The nozzle and needle are made of a carbide material for outstanding abrasion resistance. A special cap is provided for atomizing even highly viscous liquids.

Applications

Recommended for applying glaze to sanitary ware
 In addition to glaze, it can also be used with high viscosity agents and with functional agents that are highly abrasive to metal parts, such as abrasive compounds and Teflon.

Use of carbide

Some fluids applied by spraying contain hard ingredients that can abrade metal parts. When spraying such liquids, stainless steel nozzles and needles will wear quickly, leading to paint leaks and other problems. The ZP Series incorporates carbide nozzles and needles for outstanding wear resistance and reduced parts replacement frequency.

Reference drawing (mm)

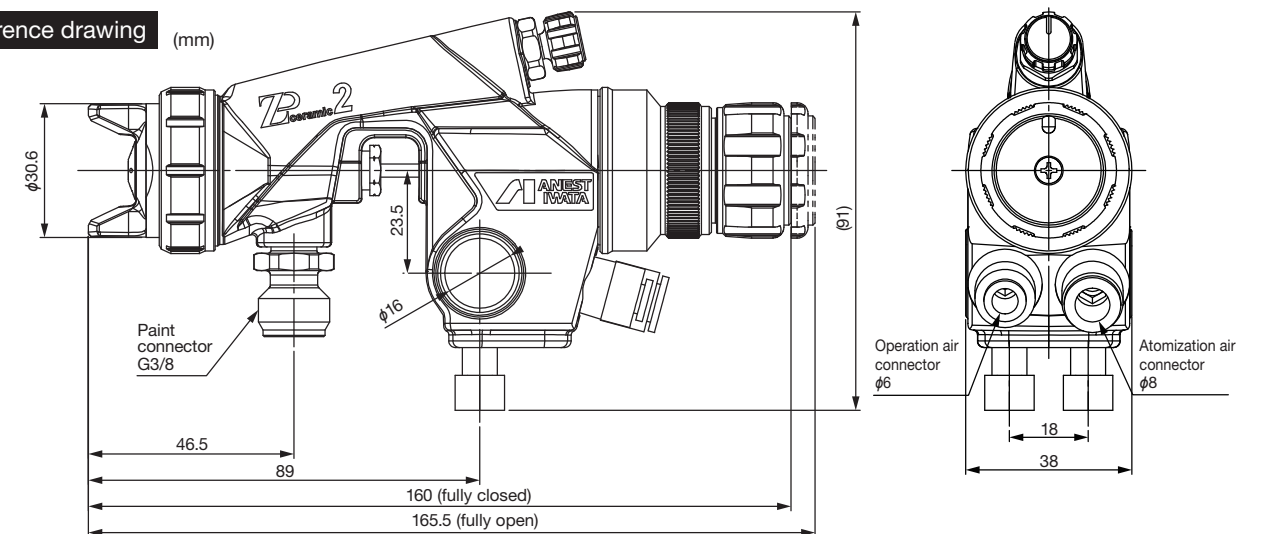

Specifications

Model	Type of feed	Nozzle orifice φmm	Recommended conditions		Air consumption L/min	Pattern width mm	Air cap model	Mass g
			Spraying air pressure* MPa	Liquid discharge rate mL/min				
ZP2-A20	Pressure	2.0	0.34	760	500	380	ZP2-R1Z	450
ZP2-A25		2.5						

* Spraying air pressure refers to the spray gun inlet pressure when the piston operation air is supplied and spraying air is flowing.
 ● The spray distance is 250 mm. ● The connector diameters are as follows: Atomization air φ8 mm tube, operation air φ6 mm tube, paint φ6 mm tube, paint G3/8
 ● Compressor requirements: 7.5 to 11 kW

2 Viscosity Conversion Table

Class	Pa·s	dPa·s (P)	mPa·s (cps)	ANEST IWATA NK-2 (s)	Ford (s)		Zahn (s)		Example viscosity	Compatible application device	Compatible spraying liquid supply unit	Compatible paint supply unit		
					#4	#3	#4	#2						
Low viscosity	0.01	0.1	10		5			16	Milk	TOF Series liquid spray gun High viscosity spray gun	CGP Series adhesive diaphragm pump	DDP/DPS-70 Series (190 mPa·s or less)	DDP/DPS-90/120 Series (300 mPa·s or less)	PPS (300 mPa·s or less)
	0.02	0.2	20	5	10	12		18	Beer					
	0.03	0.3	30	11	15	19		20						
	0.04	0.4	40	14	17	25		22	Undiluted probiotic drink solution					
	0.05	0.5	50	16	19	29		24	Gasoline engine oil (40 °C)					
	0.06	0.6	60	19	21	33		27						
	0.07	0.7	70	21	23	36		30	Diesel engine oil (40 °C)					
	0.08	0.8	80	25	26	41		34	Cooking oil					
	0.09	0.9	90	29	29	45		37	Olive oil (20 °C)					
	0.10	1.0	100	31	31	50	10	41	Jelly-type sports drink					
	0.12	1.2	120	38	36	58	11	49	Silicone adhesive					
	0.14	1.4	140	44	41	66	13	53						
	0.16	1.6	160	49	45	67	14	56	Kitchen detergent					
	0.18	1.8	180	56	51		16	74						
	0.20	2.0	200	63	56		17	82	Maple syrup					
	0.22	2.2	220	69	61		18							
	0.24	2.4	240	76	67		20		Water-based printing ink					
	0.26	2.6	260	83	72		21							
	0.28	2.8	280	88	76		22							
	0.30	3.0	300	96	83		24		FRP boat hull paint					
0.40	4.0	400				30		Laundry starch						
0.50	5.0	500				37		Yogurt						
0.60	6.0	600				44		Gelatin (50 °C)						
0.70	7.0	700				51								
0.80	8.0	800				58		Brown sauce						
0.90	9.0	900				64		Egg yolk/gum syrup						
1	10	1,000						Chocolate syrup						
2	20	2,000						Tomato ketchup						
3	30	3,000												
4	40	4,000						Kneaded miso						
5	50	5,000						Chocolate						
8	80	8,000						Mayonnaise						
10	100	10,000						Laver boiled in soy						
30	300	30,000						Hand cream						
50	500	50,000						Honey						
80	800	80,000												
100	1,000	100,000						Starch syrup						
130	1,300	130,000												
150	1,500	150,000						Pipe sealant						
180	1,800	180,000												
200	2,000	200,000						Mustard paste						
Ultra-high viscosity	1,000 or greater	10,000	1,000,000					Shortening						

* The data provided above is representative. * Use this conversion table only as a guide. * VG (Viscosity Grade) is the ISO symbol used to indicate viscosity grade.

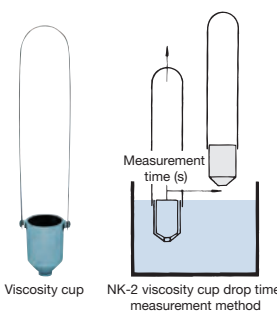

Viscosity units: Correlation between SI and CGS unit systems

- 1 Pa·s = 1,000 mPa·s = 10 P Pa·s (pascal seconds)
- 1 dPa·s = 0.1 Pa·s = 1 P dPa·s (decipascal seconds) P (poise)
- 1 mPa·s = 0.001 Pa·s = 1 cps mPa·s (millipascal seconds) cps (centipoise)

- * The NK-2 viscosity cup is a viscosity measuring device that uses the drop time measurement method.
- * The NK-2 viscosity cup is a device for easily determining the viscosity of a fluid, but is not a measuring instrument, and the values determined cannot be used for other purposes.
- * The values determined using the NK-2 viscosity cup are reference figures. They are not guaranteed.
- * The values obtained may vary depending on factors such as type of fluid measured, environmental factors, and methods used. Note that the margin of error increases for measurements of 100 s / NK-2 or greater.
- * Viscosity conversions comply with JS-10/20/50/100/200 as specified in JIS 8809-78 "Standard liquids for calibrating viscometers."
- * The viscosity conversion table provides summary values obtained from viscosity cup measurements. The conversion figures obtained from this table are reference values. They are not guaranteed.
- * 1 P = 100 cP = 0.1 Pa·s

SPECIALTY PRODUCT

3

Special Purpose Automatic Spray Guns



These automatic spray guns offers specifications designed specifically for spraying areas that present problems with typical automatic spray guns, such as inner surface application, pinpoint application, and marking application.

3

Special Purpose Automatic Spray Guns
(For inner surface application, pinpoint application, marking application)

RK1-A05-0690/A05-09150/A06-12180

Single-side angle type for small area application

These spray guns feature a single-side angle spray gun cap.
A choice of three spraying angles (4°, 14°, 19°) is available. The variable angle type is also available.

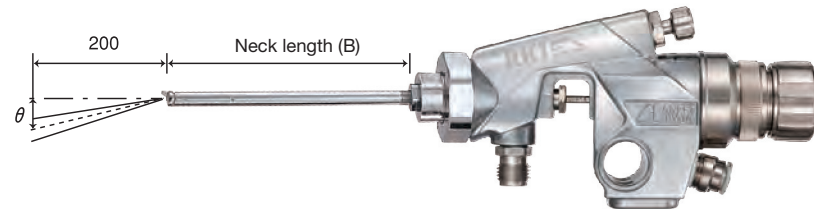

General purpose type

Applications

Recommended for painting inside cylindrical objects that can be rotated, pinpoint applications, and marking applications
Recommended for spraying liquids such as paint, anti-corrosion agents, and functional agents (with viscosity not exceeding 15 s / NK-2 [40 mPa·s])

Coating inside cylinders

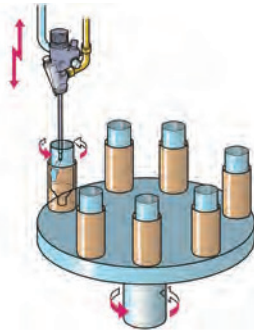

Identification marking of defective items

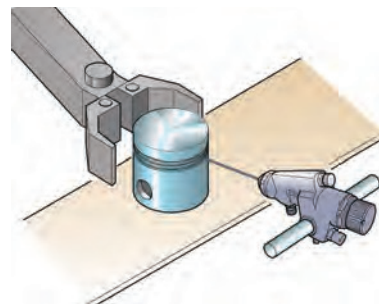

Reference drawing (mm)

RK1-A05-0690/A05-09150/A06-12180

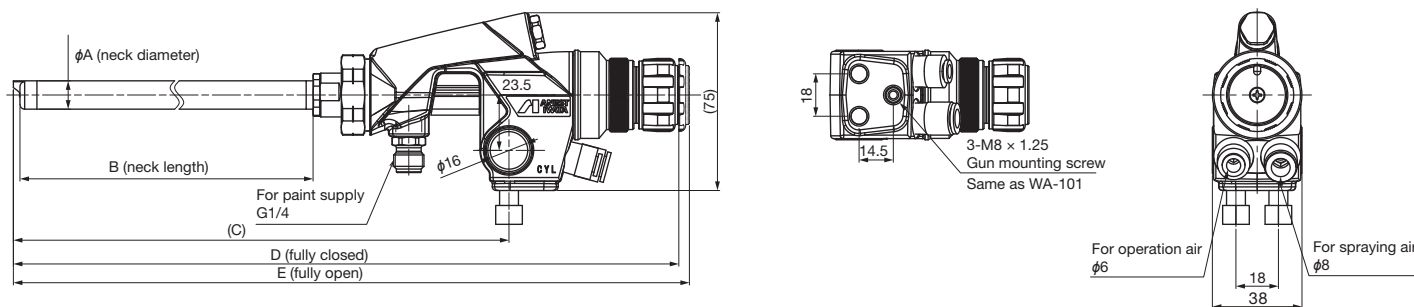

Model	A	B	C	D	E
RK1-A05-0690	6	90	175	247	252
RK1-A05-09150	9	150	236	308	312
RK1-A06-12180	12	180	266	338	343

Specifications

Previous model	Model	Type of feed	Nozzle orifice φmm	Recommended conditions		Air consumption L/min	Pattern width mm	Mass g	Workpiece diameter φmm	Neck diameter φmm	Neck length mm	Spray pattern	Pattern deflection angle
				Spraying air pressure* MPa	Liquid discharge rate mL/min								
WA-0609	RK1-A05-0690	Pressure (gravity possible)	0.5	0.29	4	35	32	455	9 to 15	6	90	Round/flat	Approx. 4°
WA-0915	RK1-A05-09150		0.5		9	55	36	490	12 to 25	9	150		Approx. 14°
WA-1218	RK1-A06-12180		0.6		17	73	48	535	15 to 30	12	180		Approx. 19°

* All models are manufactured to order.
● The spray distance is 200 mm. ● The connector diameters are as follows for all models: Air G1/4 (male), liquid G1/4 (male) ● Liquid viscosity: 20 s / NK-2
● Compressor requirements: RK1-A06-12180/A05-09150/A05-0690: Min. 0.40 kW

3

Special Purpose Automatic Spray Guns
(For pinpoint application, marking application)

AS-80-001

Close-range spraying of small items and marking applications

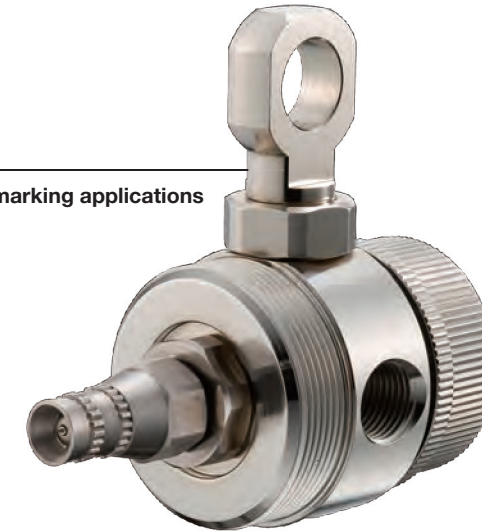

High performance type

Fitted at the tip with an airbrush atomizing head, this round spraying type spray gun is capable of spraying at even closer range than close-range spray guns, allowing lines only a few mm wide to be drawn.

Applications

Recommended for spraying liquids such as paint, anti-corrosion agents, and functional agents (with viscosity not exceeding 10 s / NK-2 [30 mPa·s])

Usage example



Reference drawing (mm)

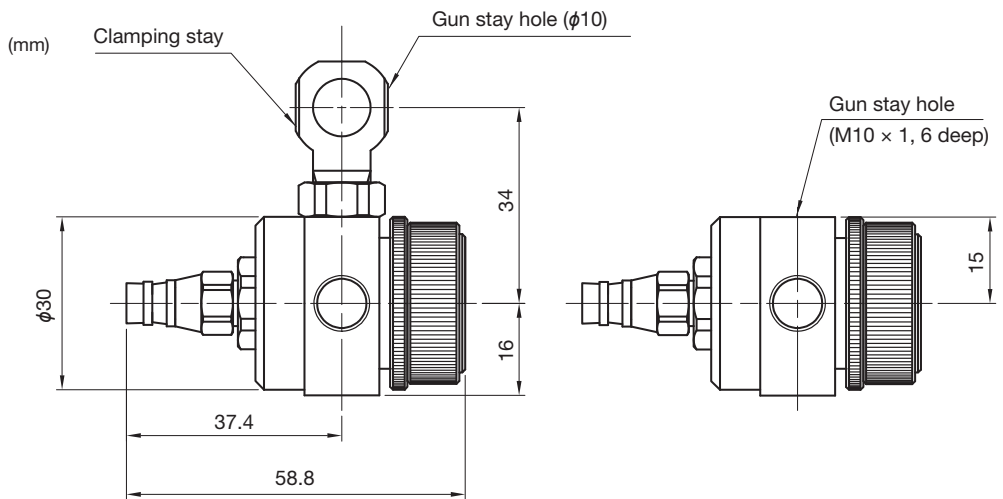

Specifications

Model	Type of feed	Nozzle orifice φmm	Recommended conditions		Air consumption L/min	Pattern width mm	Mass g
			Spraying air pressure* MPa	Liquid discharge rate mL/min			
AS-80-001	Pressure (gravity possible)	0.4	0.29	5 to 12	15	5 to 15 ²	175

*1 Spraying air pressure refers to the spray gun inlet pressure when the piston operation air is supplied and spraying air is flowing.

*2: Pattern widths will vary depending on spray distance and liquid discharge rates.

● The connector diameters are as follows: Atomization air Rc1/8 (female), operation air Rc1/8 (female), liquid Rc1/8 (female) ● Gun clamping screw thread size: Hole for M10 x 1 bolt

3

Special Purpose Automatic Spray Guns
(For spraying with minimal scatter)

TOF-6RB-S2

Mini automatic gun with multi-hole cap



General purpose type

Spray example

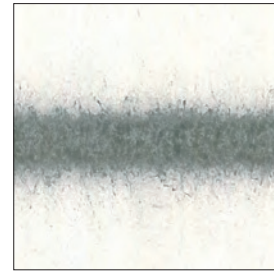

Conventional spray gun

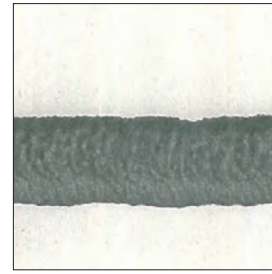

TOF-6RB-S2
(gun distance: 5 mm)

The air cap incorporates multiple holes (air guard) around the outside to allow air to escape, significantly reducing scattering. Designed for round spraying, this spray gun is ideal for pinpoint applications, particularly effective on flat surfaces.

Applications Recommended for spraying liquids such as vulcanizing adhesive, paint, anti-corrosion agents, and functional agents (with viscosity not exceeding 40 s / NK-2 [130 mPa·s])

Reference drawing (mm)

TOF-6RB-S2

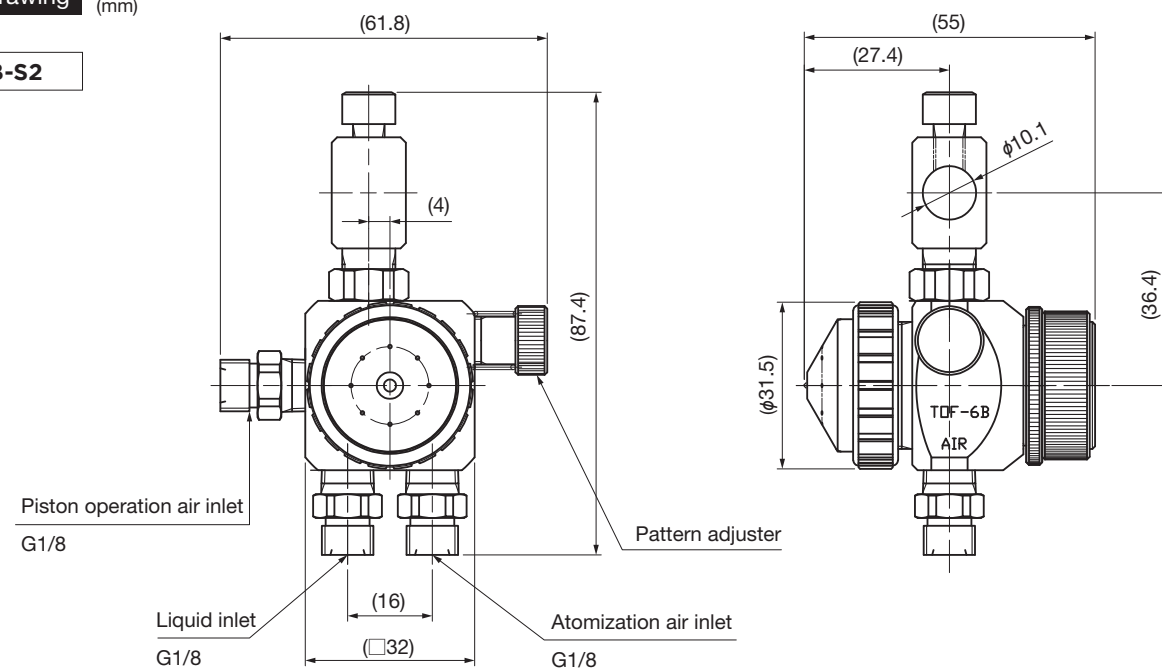

Specifications

Model	Type of feed	Nozzle orifice φmm	Recommended conditions		Air consumption L/min	Pattern width mm	Mass g
			Spraying air pressure* MPa	Liquid discharge rate mL/min			
TOF-6RB-S2	Pressure (gravity)	0.5	0.29	60	50	70	350

* Spraying air pressure refers to the spray gun inlet pressure when the piston operation air is supplied and spraying air is flowing.
 ● The spray distance is 300 mm (spraying with water). ● The connector diameters are as follows: Atomization air G1/8 (male), pattern air G1/8 (male), operation air G1/8 (male), liquid G1/8 (male)
 ● Gun clamping screw thread size: 10 mm (Refer to TOF-6B on p. 21-22)

3

Special Purpose Automatic Spray Guns
(For spraying with minimal scatter)

AS-30-111

Automatic gun with multi-hole cap



High performance type

Spray example

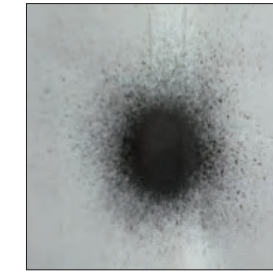

Conventional spray gun

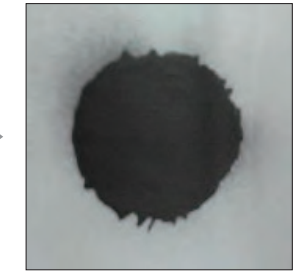

AS-30-111
(gun distance: 5 mm)

High performance version of TOF-6RB-S2 spray gun. The atomization air and guard air can be controlled independently to make optimal settings to suit a wide range of applications.

Applications Recommended for spraying liquids such as vulcanizing adhesive, paint, anti-corrosion agents, and functional agents (with viscosity not exceeding 40 s / NK-2 [130 mPa·s])

Reference drawing (mm)

AS-30-111

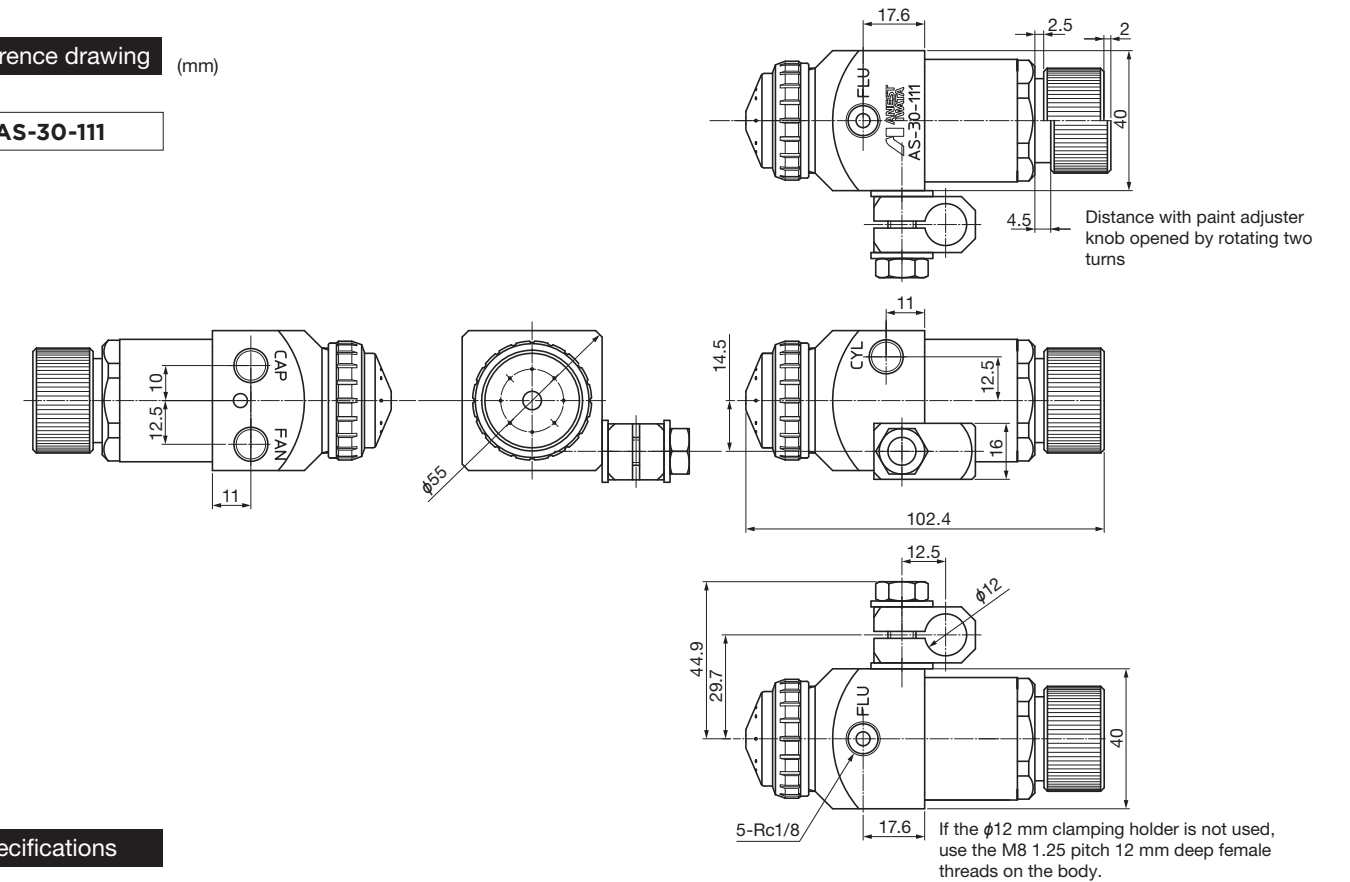

Specifications

Model	Type of feed	Nozzle orifice φmm	Recommended conditions		Air consumption L/min	Pattern width mm	Mass g
			Spraying air pressure* MPa	Liquid discharge rate mL/min			
AS-30-111	Pressure	0.8	0.26	100	350	60	350

* Spraying air pressure refers to the spray gun inlet pressure when the piston operation air is supplied and spraying air is flowing.
 ● The connector diameters are as follows: Atomization air Rc1/8 (female), pattern air Rc1/8 (female), operation air Rc1/8 (female), liquid Rc1/8 (female)

3

Special Purpose Automatic Spray Guns
(For spraying with minimal scatter)

AS-80-011/-013

Ultra compact spray guns
Aluminum/stainless steel construction

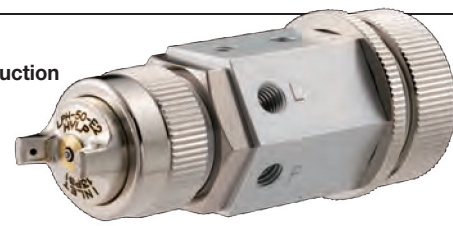

AS-80-011



AS-80-013

High performance type



Ultra compact dimensions allow flat spraying with suppressed scattering. The atomization air and pattern air can be controlled independently. Internal recirculation configuration ensures compatibility with liquids susceptible to high precipitation.
AS-80-011 body material: Aluminum
AS-80-013 body material: Stainless steel

Applications Recommended for spraying liquids such as paint, anti-corrosion agents, and functional agents (with viscosity not exceeding 25 s / NK-2 [80 mPa·s]).

Reference drawing (mm)

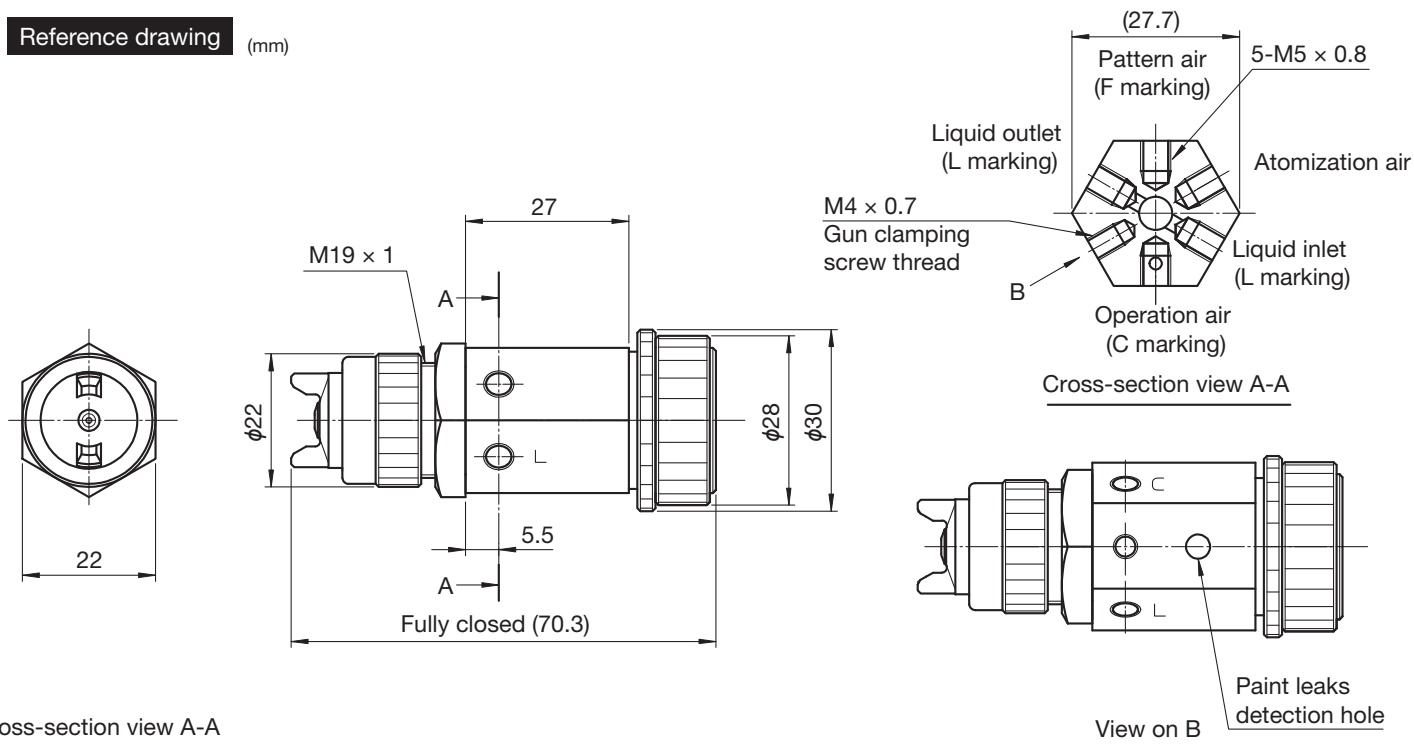

Cross-section view A-A

View on B

Specifications

Model	Type of feed	Nozzle orifice ϕ mm	Recommended conditions		Liquid discharge rate mL/min	Air consumption L/min	Pattern width mm	Mass g
			Atomization	Pattern				
AS-80-011	Pressure	1.0	0.09	0.079	55	50	100	120
AS-80-013								180

* Spraying air pressure refers to the spray gun inlet pressure when the piston operation air is supplied and spraying air is flowing.

● The connector diameters are as follows: Liquid M5 x 0.8, air M5 x 0.8

PAINTING EQUIPMENT

4

Supply Equipment / Related Products



Equipment required to supply paint, such as pumps and paint regulators, and related equipment such as hoses and joints

Supply Pump Selection Guide

Points to note and comparisons of recommended paint pump products

- Select models from the chart below based on parameters such as **Discharge rate and Applications**.
- Select the pump discharge rate based on **Discharge rate at 30 cycles/min**. (See explanation below for more information.)
- ★ indicates **the most recommended model** for a particular paint pump type. (☆ indicates the second most recommended model. These products offer the greatest versatility and are likely the right choice for those in doubt.)

Diaphragm pumps

These are air-driven double diaphragm pumps that combine **simple design with high durability**. They are suitable for a wide range of applications, including low discharge rate spray painting, use with multiple spray guns, and paint transfer.

Bellows seal pumps

Bellows seal pumps are air-driven double-action piston pumps that use a bellows seal configuration for sliding parts. They offer **high pressure ratios and high discharge performance to ensure stable paint supply even with high viscosity paints and multiple spray guns**.

Plunger pumps

Plunger pumps are air-driven double-action plunger paint pumps. They can also be used for **high-pressure supply and recirculation systems**.

- ★ Recommendation No. 1
- ☆ Recommendation No. 2

Typical applications are listed here. Applications are also provided in the specifications tables for individual products. Refer to both when selecting products.

Pump type and size	Diaphragm pump						Diaphragm pump		Bellows seal pump	Plunger pump	Pump type and size
	Small		Medium		Large		Large		Large	Medium	
Pump model											Pump model
Recommended!	DDP-70B	DDP-70BN	★ DDP-90E	DDP-90EN	★ DDP-120B	DDP-120BN	DDP-160D	DDP-160DN	BSP-A030C-N	PP-7021B	Recommended!
Wetted parts material (pump body)*1	Aluminum	Stainless steel	Aluminum	Stainless steel	Aluminum	Stainless steel	Aluminum	Stainless steel	Stainless steel	Aluminum/steel	Wetted parts material (pump body)*1
At 30 cycles/min	0.6 L/min		1.5 L/min		4.5 L/min		10 L/min		17.1 L/min	2.7 L/min	Discharge rate
Air consumption (0.7 MPa)	Approx. 25 L/min		Approx. 55 L/min		Approx. 80 L/min		Approx. 250 L/min		Approx. 625 L/min	Approx. 130 L/min	Air consumption (0.7 MPa)
Allowable viscosity (guideline values)*2	Max. 60 s / NK-2 Max. 190 mPa·s		Max. 100 s / NK-2 Max. 300 mPa·s		Max. 100 s / NK-2 Max. 300 mPa·s		Max. 3,000 mPa·s		Max. 10,000 mPa·s	Max. 100 s / NK-2 Max. 300 mPa·s	Allowable viscosity (guideline values)*2
Pressure ratio (paint:air)	1:1		1:1		1:1		1:1		3:1	2.3:1	Pressure ratio (paint:air)
Operating air pressure range	0.15 to 0.7 MPa		0.15 to 0.7 MPa		0.15 to 0.7 MPa		0.15 to 0.83 MPa		0.15 to 0.7 MPa	0 to 0.7 MPa	Operating air pressure range
Maximum paint pressure (theoretical values)	0.7 MPa		0.7 MPa		0.7 MPa		0.83 MPa		2.1 MPa	1.7 MPa	Maximum paint pressure (theoretical values)
Connector size	G1/4 male		G1/4 male		G1/4 male		G1/4 male		Rc3/8 female	G1/4 male (PPS-102C)	Air inlet
Paint inlet	Rc1/4 female		G1/2 male		G1/2 male		G3/4 male		Rp1 female	G1/4 male (PPS-102C)	Paint inlet
Paint outlet	Rc1/4 female		Rc3/8 female		Rc3/8 female		G3/4 male		Rp1 female	G1/4 male (PPS-102C)	Paint outlet
Discharge rate per cycle	20 mL/cycle		50 mL/cycle		150 mL/cycle		330 mL/cycle		570 mL/cycle	90 mL/cycle	Discharge rate per cycle
Maximum cycles	300 cycles/min		200 cycles/min		200 cycles/min		200 cycles/min		70 cycles/min	50 cycles/min	Maximum cycles
Maximum discharge rate*3	6 L/min		10 L/min		30 L/min		66 L/min		40 L/min	4.5 L/min	Maximum discharge rate*3
Pump unit	DDP-70B	DDP-70BN	DDP-90E	DDP-90EN	DDP-120B	DDP-120BN	DDP-160D	DDP-160DN	BSP-A030C-N	PPS-102C	Pump unit
Stand type	Customizable	Customizable	★DPS-90E	DPS-90EN	★DPS-120B	DPS-120BN	—	—	—	—	Stand type
Wall-mounted type	☆DPS-704C	DPS-704CN	DPS-904E	DPS-904EN	DPS-1204B	DPS-1204BN	—	—	—	—	Wall-mounted type
Handy type with 5 L hopper	☆HDP-705C	HDP-705CN	—	—	—	—	—	—	—	—	Handy type with 5 L hopper
Direct-mounted type	☆DPS-70C	Customizable	—	—	—	—	—	—	—	—	Direct-mounted type
Transfer pump	DPS-70TC	Customizable	—	—	—	—	—	—	—	—	Transfer pump
Raising/lowering stand type	DPS-70LC	DPS-70LCN	☆DPS-90LE	DPS-90LEN	DPS-120LB	DPS-120LBN	—	—	—	—	Raising/lowering stand type
Tank-mounted type	DPS-702C	DPS-702CN	DPS-902E	DPS-902EN	DPS-1202B	DPS-1202BN	—	—	—	—	Tank-mounted type
Raising/lowering stand type	DPS-70LPC	DPS-70LPCN	DPS-90LPE	DPS-90LPEN	DPS-120LPB	DPS-120LPBN	—	—	—	—	Raising/lowering stand type

*1 Aluminum pumps use plated steel components for joints and other wetted parts. We recommend using stainless steel pumps for applications involving fluids that may cause corrosion.

*2 The allowable viscosity will vary depending on the inlet hose and discharge piping.

*3 Value at the paint outlet when using the pump on its own with no load and clean water as the fluid

Recommended product list



Major applications

- Resin coating Examples: automotive components, mobile phones, household appliances
- Woodwork coating Examples: furniture, musical instruments
- Vehicle coating Examples: automobiles, trucks, rail vehicles
- Liquid application Examples: adhesive, mold release agent, lubricant
- Metal coating Examples: construction machinery, machine tools, steel furniture, electrical distribution boards
- Liquid feeding Examples: paint, thinner

Reasons for selecting discharge rate for 30 cycles/min

Select a paint pump to suit the required discharge rate. Supplying paint using paint pumps with greater capacity than required is wasteful. While the maximum discharge rate (at zero load) is one indicator for determining paint pump performance, it is important to compare this to the discharge rate per paint pump cycle based on the discharge rate required for actual painting work. **Fewer operating cycles will increase pump durability and help prevent pulsation. Typically, the ideal setting will not exceed 30 cycles/min.** Start with this figure when selecting a paint pump.

Pressurized stainless steel tanks

Features
The tank interior has a mirror finish to minimize paint or solution adhesion and facilitate cleaning.

- COT-3M
- COT-10/10M/10HL
- COT-20B/20BM/20BHL

The range consists of tanks with actual capacities of 3 L, 10 L, 25 L, and 31 L. Also available are models with agitators and level gauges.

Supply Control / Options

PR-5B Series

Paint regulators

The products in the PR-5B Series are diaphragm type paint regulators that help maintain constant paint pressure and discharge rates to ensure uniform paint film thickness and paint quality control. The line of products includes two types to suit the required pressure adjustment range. As with diaphragm pumps, the wetted parts have a mirror finish to facilitate cleaning.

Model	PR-5B
Type	General purpose
Wetted parts material (body)	Aluminum
Pressure adjustment range	0 to 0.6 MPa
Maximum flow rate	2.0 L/min

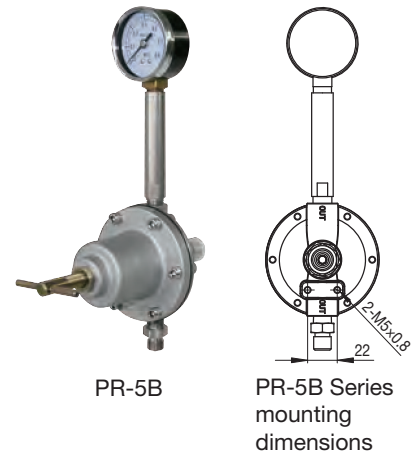

FCV-3, FCV-5 Series

Flow control valves

Products in the FCV-3 and FCV-5 Series are air-operated paint regulators that allow paint pressure and discharge rate to be adjusted remotely. In spray environments involving robots or reciprocators, they can be mounted close to automatic spray guns to eliminate discharge rate variations due to height differences. The FCV-31-R4/R8 and FCV-5-R1/R4/R8 have different pressure bearing areas for the diaphragm air and paint chambers, making them ideal for low discharge rate adjustments.

Model	FCV-3	FCV-31	FCV-31-R4	FCV-31-R8
Type	General purpose	With dump valve function	With dump valve function; for low flow-rate/low pressure discharge	
Wetted parts material (body)	Aluminum/Stainless steel			
Diaphragm pressure bearing diameter ratio*	1:1	1:4	1:4	1:8
Guideline discharge rate	1,100 mL/min or greater	35 to 100 mL/min	35 to 100 mL/min	20 to 50 mL/min

* This diaphragm pressure bearing diameter ratio will differ from the ratio between the air adjustment pressure and secondary paint pressure (after pressure adjustment). Note that while a larger diaphragm pressure bearing diameter ratio allows greater secondary paint pressure adjustment, the maximum pressure will be lower.

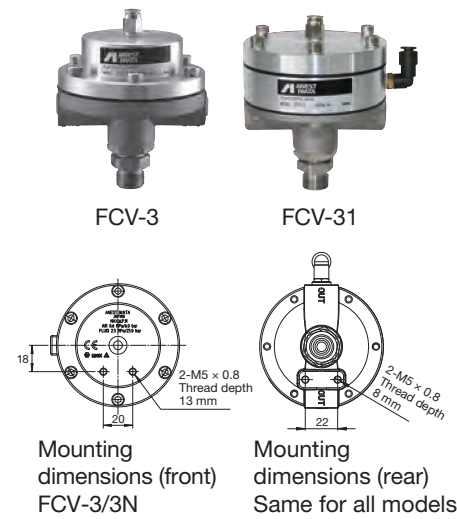

PR-B5B Series

Back pressure valves

Integrating these valves together with a paint regulator into the paint piping makes it possible to set up a paint recirculation system. They prevent precipitation of paints susceptible to precipitation, such as metallic paints, as well as ensure stable paint pressure when connected to multiple spray guns. They can be mounted on the paint return side of the paint recirculation system to allow fixed-quantity control.

Model	PR-B5B
Wetted parts material (body)*	Aluminum
Pressure adjustment range	0 to 0.6 MPa
Maximum flow rate	2.0 L/min

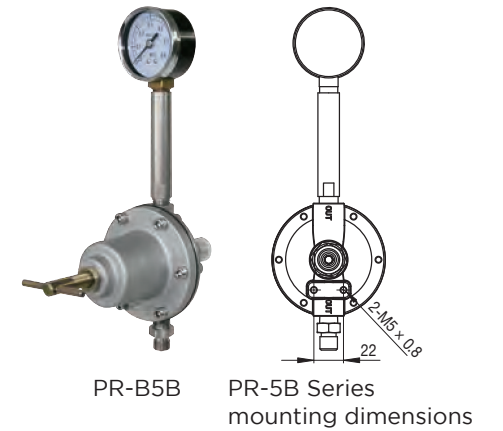

PR-5B-S1

Paint regulator kit

Adding one paint regulator kit (PR-5B-S1) allows two spray guns to be connected. A stainless steel model is also available. (PR-5BN-S1)

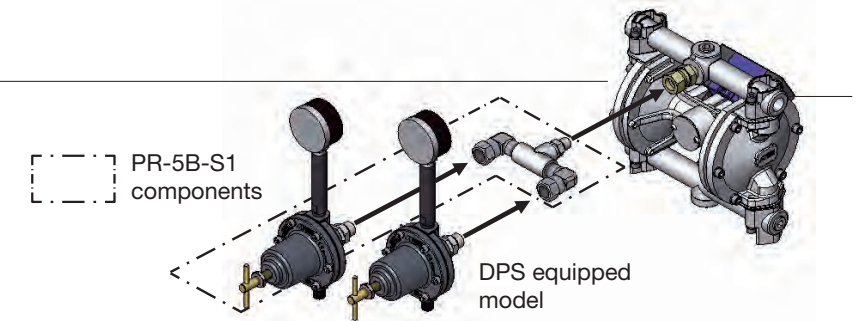

TF-7 Series

Intermediate paint filters

Eliminates debris that can cause painting defects. This is used attached to the paint outlet of diaphragm pumps or paint tanks or between paint hoses.

Paint intermediate filter to remove debris

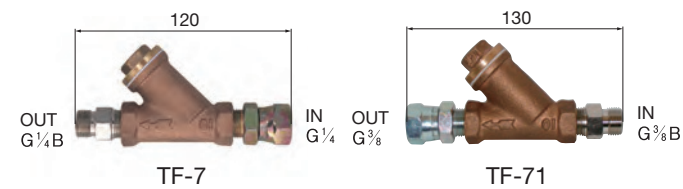

Model	TF-7	TF-71
Wetted parts material (body)	Bronze casting	
Paint inlet	G1/4 cap nut	G3/8 cap nut
Paint outlet	G1/4B	G3/8B
Paint filter	100 mesh	
Optional filter	150/200 mesh	
Maximum operating paint pressure	1.27 MPa	

* The PR-5B, FCV-3, PR-B5B, and PR-5B-S1 are also available with stainless steel specifications. For detailed specifications, refer to the ANEST IWATA Paint Supply and Coating System Equipment catalog or the official website.

FCV-5 Features

Paint passage interiors with springless construction

This eliminates faulty operation caused by material adhering to pressure adjustment springs.

Unidirectional interior construction

The interior paint flow is limited to one direction, eliminating paint stagnation and improving paint buildup to facilitate cleaning.

* 50 % reduction in cleaning fluid compared to previous ANEST IWATA models

Model	FCV-5-R1	FCV-5-R4	FCV-5-R8
Type	With dump valve function	With dump valve function; for low flow-rate/low pressure discharge	
Wetted parts material (body)	Stainless steel/fluorine resin		
Diaphragm pressure bearing diameter ratio*	1:1	1:4	1:8
Guideline discharge rate	100 mL/min or greater	35 to 100 mL/min or greater	20 to 50 mL/min or greater

* This diaphragm pressure bearing diameter ratio will differ from the ratio between the air adjustment pressure and secondary paint pressure (after pressure adjustment). Note that while a larger diaphragm pressure bearing diameter ratio allows greater secondary paint pressure adjustment, the maximum pressure will be lower.

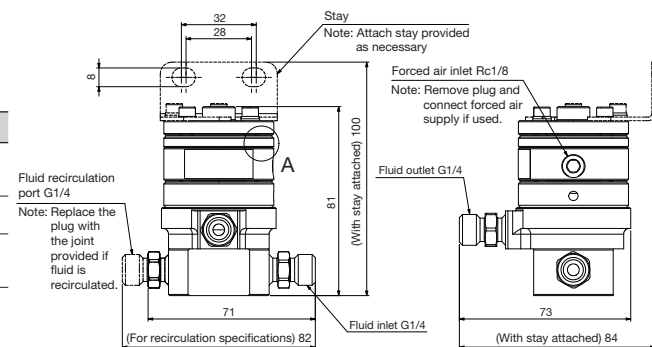

Hoses and joints

PHF

Paint hose

Fluorine liner hose



Non-adhesive with excellent water repellency and high smoothness for easy liquid changeover and cleaning. Complies with Japanese Food Sanitation Act for peace of mind.

PHN

Paint hose

Nylon hose



Offers high strength and outstanding resistance against water and solvents.

PHU

Paint hose

Urethane hose



Offers excellent flexibility for easy routing.

EAHU

Air hose

Air hose with grounding wire



Incorporates a grounding wire to ensure safety.

Paint hose materials and properties

PHF Fluorine liner hose

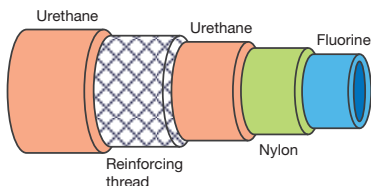

PHN Nylon hose

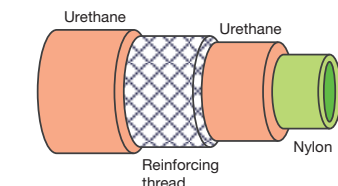

PHU Urethane hose

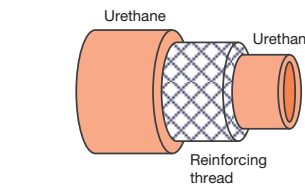

Property	PHF Fluorine liner hose	PHN Nylon hose	PHU Urethane hose
Flexibility	Good	N/A	Excellent
Ease of cleaning	Excellent	Average	N/A
Non-adhesiveness	Excellent	Average	N/A
Durability	Excellent	Excellent	Average
Water resistance	Excellent	Average	N/A

Air Joints

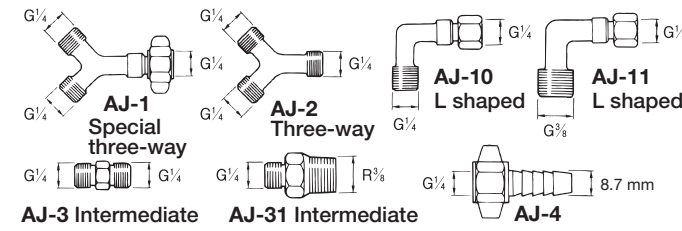

Air Valve

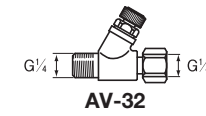

Urethane Air Hose Joints

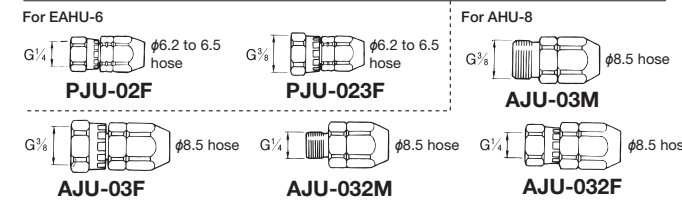

* Use AJU-02F/AJU-02M joints for former AHU-6 urethane air hoses.

Quick Joints for Air (*1)

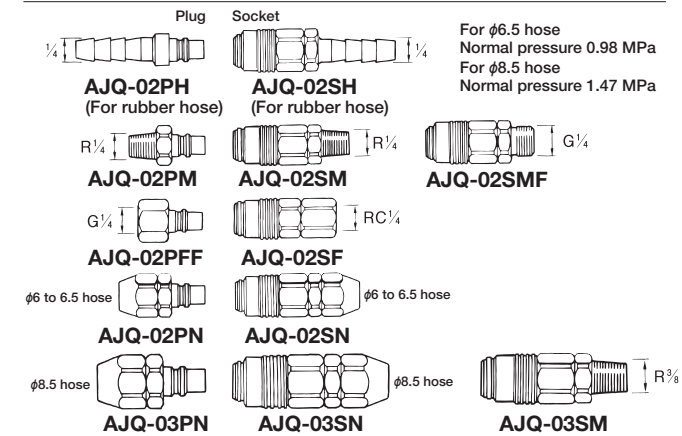

- (*1) ● For use with air hoses only. Never use with paint hoses.
 ● If a ground wire is not used, the joint can be connected in a conventional manner without drawing out the ground wire. However, hoses should be labeled appropriately to avoid mistaken use of hoses with a ground wire and hoses without a ground wire.

Air Hoses (*2)

Model	Material	Inner dia. × Outer dia. × Length	Max. operating pressure
EAHU-620	Urethane with ground wire	φ6.2 × φ9.3 × 20 m	1.47 MPa
EAHU-630		φ6.2 × φ9.3 × 30 m	
EAHU-650		φ6.2 × φ9.3 × 50 m	
EAHU-6100		φ6.2 × φ9.3 × 100 m	
EAHU-820	Urethane	φ8.5 × φ12 × 20 m	
EAHU-8100		φ8.5 × φ12 × 100 m	
AHU-820B		φ8.5 × φ12 × 20 m	
AHU-830B		φ8.5 × φ12 × 30 m	
AHU-850B		φ8.5 × φ12 × 50 m	
AHU-8100B		φ8.5 × φ12 × 100 m	

CAUTION Precautions when using air hoses with ground wire (*2)

- These hoses include a ground wire, but the connected devices must be grounded.
- Never use as air hoses for supply pumps used with low-resistance paint static spraying units or insulated bases whether or not the ground wire is used. In such cases, use a urethane air hose (AHU-8) or paint hose (PHU/PHN) as the air hose.
- When using the ground wire, ground in accordance with the instruction manual and periodically check conductivity using a tester. Never use hoses if they are degraded or have broken wires; replace immediately with a new hose.
- For use as air hoses only. Never use as paint hoses.
- If a ground wire is not used, the joint can be connected in a conventional manner without drawing out the ground wire. However, hoses should be labeled appropriately to avoid mistaken use of hoses with a ground wire and hoses without a ground wire.

Paint Joints

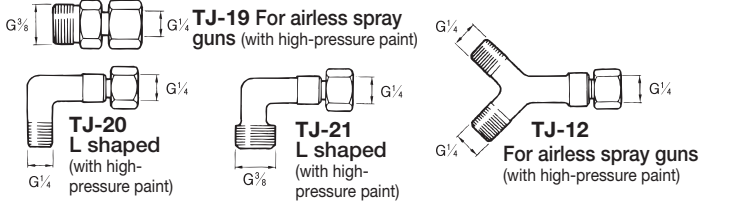
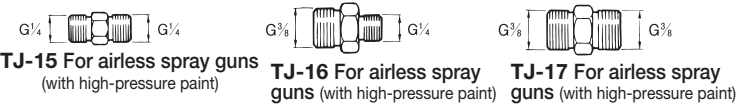
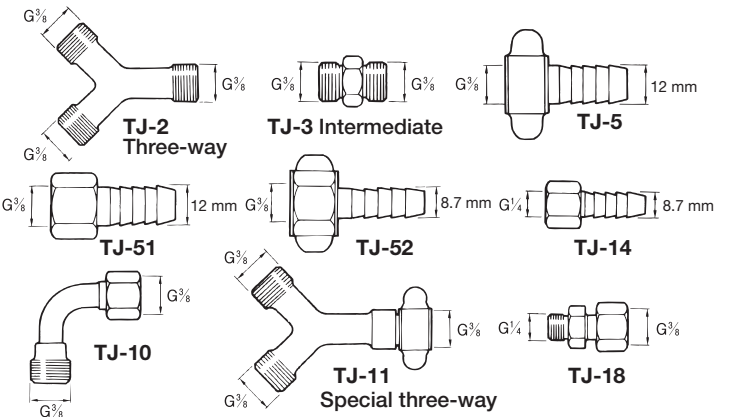

Paint Hose Joints

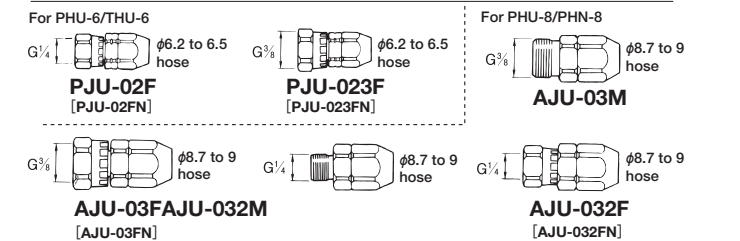

* Models in brackets are stainless steel models.

Paint Quick Joints

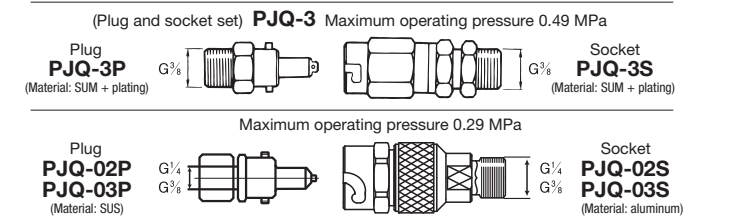

Paint Hoses (*3)

Model	Material	Inner dia. × Outer dia. × Length	Max. operating pressure		
PHU-620	Urethane	φ6.2 × φ9.3 × 20 m	0.69 MPa		
PHU-6100		φ6.2 × φ9.3 × 100 m			
PHU-820		φ8.7 × φ12 × 20 m			
PHU-8100		φ8.7 × φ12 × 100 m			
PHN-620	Nylon	φ6.5 × φ9.5 × 20 m		0.69 MPa	
PHN-6100		φ6.5 × φ9.5 × 100 m			
PHN-820		φ8.9 × φ12.1 × 20 m			
PHN-8100		φ8.9 × φ12.1 × 100 m			
PHF-620	Urethane with fluorine-based inner lining	φ6.5 × φ9.5 × 20 m			0.69 MPa
PHF-6100		φ6.5 × φ9.5 × 100 m			
PHF-820		φ8.9 × φ12.1 × 20 m			
PHF-8100		φ8.9 × φ12.1 × 100 m			
THU-620	Urethane (twin)	φ6.2 × φ9.3 × 2 × 20 m	0.69 MPa		
THU-6100		φ6.2 × φ9.3 × 2 × 100 m			

* The THU-6 Series twin hoses for air feature orange threads and have the model printed on them.

CAUTION Precautions on paint hose selection (*3)

- Do not use urethane paint hoses (PHU/THU) with highly-dissolving or reactive paints or thinners such as ketone-based solvents, two-pack reaction paints, or urethane-based paints. These products may cause the hose to split, allow paint to spray out, and generate various hazards. Use nylon paint hoses (PHN) instead.

Safety Precautions

- Use precautions
 1. Electrostatic painting machines are spray guns specifically designed for painting. Do not use for any other purposes.
 2. Carefully read the relevant instruction manuals before use.
 3. Do not attempt to modify products. Modification may impair performance or result in failure.
- Other precautions
 1. The values provided in this catalog are obtained using ANEST IWATA test paints. Actual values may vary depending on the paint and conditions used.

- The products described in this catalog are intended for use in Japan. When exporting products purchased in Japan overseas, check in advance to confirm that they comply with applicable regulations and safety standards within the corresponding country.
- The specifications provided in this catalog are subject to change without notice to reflect product improvements.
- The photos and information provided in this catalog may differ from the actual products due to specification changes.

SUSTAINABLE DEVELOPMENT GOALS

■ Inquiries

 **ANEST IWATA Corporation**

ANEST IWATA Contact Center

 **0800-100-1926**

Hours: 8:45 am - 12:10 pm and 1:00 pm - 5:30 pm weekdays
(Not available weekends, public holidays, summer holidays, year-end and new year holidays, or holidays specified by ANEST IWATA)

<https://www.anest-iwata.co.jp/>

Official website



 **Active** with Newest Technology

- This catalog uses FS Youths coated paper.
A portion of the funds set aside to create and publish this catalog will be donated to mental care and educational support programs for orphans of the Great East Japan Earthquake.
- This catalog is made from raw materials from properly managed FSC® certified forests and other managed sources.
- This catalog is printed using ink that is free of volatile organic compounds.
- The specifications provided in this catalog are subject to change without notice to reflect product improvements.
- The photos and information provided in this catalog may differ from the actual products due to specification changes.

Printed in Japan CAT No.CT-99981000-00 2023.3 NP.0★0

